



MAX SYSTEM

ADAPTABLE  
LABORATORY  
FURNITURE

2025



 **Hamilton**  
LABORATORY SOLUTIONS

## Hamilton | Laboratory Solutions — MAX System



### MAX/Lab



Achieve maximum above work surface storage with **MAX/Lab**® furniture. Service lines and height adjustable components are utilized with 12" wide free-standing double uprights.



### MAX/Mobile



Obtain the appearance and functionality of permanent workstations with **MAX/Mobile**® furniture. Components are designed for maximum adaptability.



### MAX/Wall



Create fully enclosed rooms with the **MAXWall**® utility wall system. A 6" wide core structure supports services and utilities.



### MAX/System Components



Complete your lab with components which are universal to the **MAX**® System. Select base cabinets, shelving, work surfaces, task lighting and more.

# Hamilton | Laboratory Solutions — Adaptable Laboratory Furniture

## Laboratory Furniture Solutions

- **Adjustable** – Meet ADA accessibility requirements with only minor adjustments
- **Ecological** – Reuse Hamilton MAX System components and avoid landfill excess
- **Economical** – Realize savings by minimizing structural connections and floor penetrations
- **Flexible** – Adapt quickly to changes in lab processes and personnel
- **Movable** – Relocate mobile units as needed to expedite laboratory procedures
- **Practical** – Increase productivity with minimal downtime using interchangeable components



# Hamilton | Laboratory Solutions MAX System

Island Core



MAX/Lab

Wall Core

Vertical Overhead Service Carrier

Mobile Workstation



MAX/Mobile

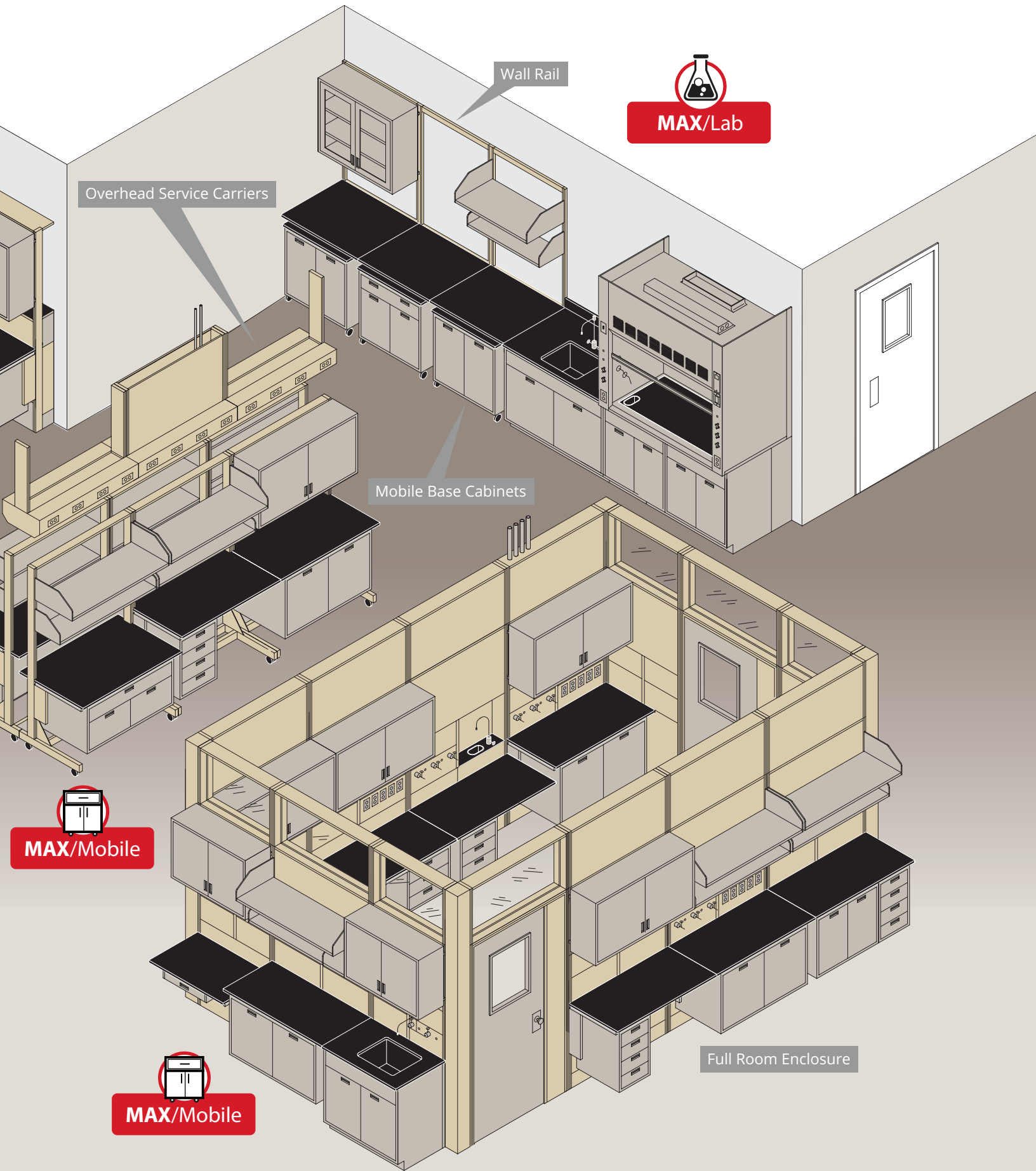

Wall Rail



**MAX/Lab**

Overhead Service Carriers

Mobile Base Cabinets



**MAX/Mobile**



**MAX/Mobile**

Full Room Enclosure



## Laboratory Furniture Support Structures

### Core Support

- Accommodates all major lab services
- Supports maximum above-counter storage
- Anchored to the floor with a 12" depth
- Wall cores are 8.75" deep and anchor to the wall and floor
- Use to create an island, wall, or peninsula
- Wide range of available heights

### Panel Support

- Cantilevered work surfaces
- Suspended storage unit
- Upper island panels
- Provides support structure where no plumbed services are required
- Easily fastened to adjacent panels or connected to adjacent cores
- Leveling glides included for ease of installation

### Wall Rail Support

- Cantilevered work surfaces
- Shelves
- Attaches to wall to provide support structure where no services are required
- For areas requiring light load-bearing capacities
- Above-counter and full-height systems available
- Options include insert panels, rail covers, and island supports

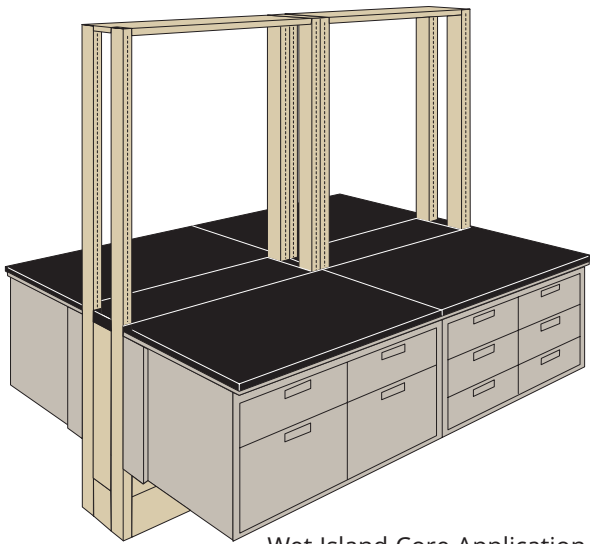

Wet Island Core Application

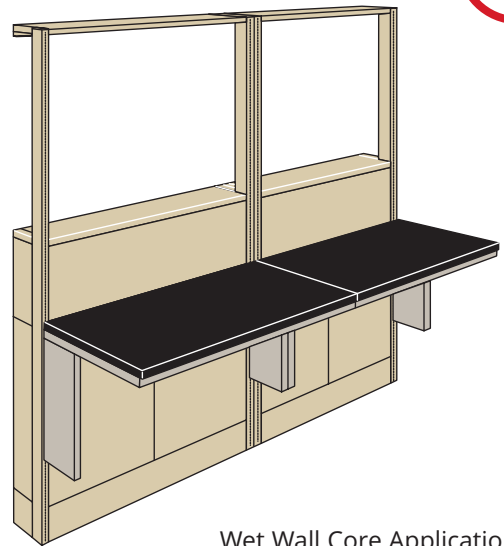

Wet Wall Core Application

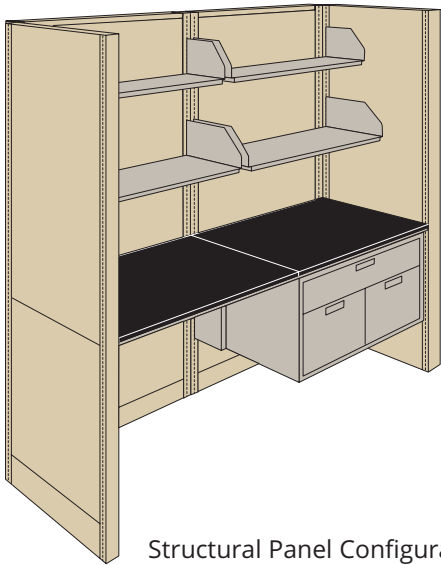

Structural Panel Configuration

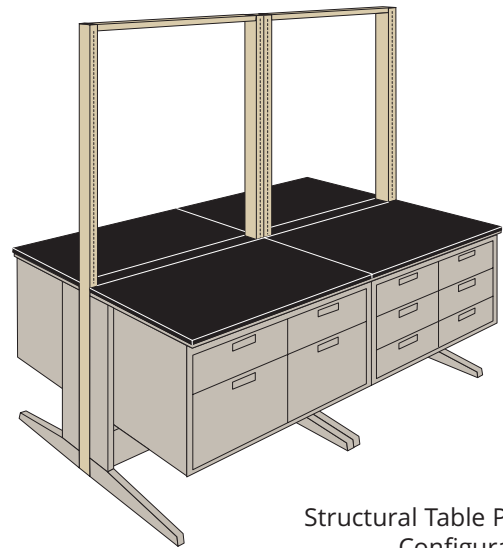

Structural Table Panel Configuration

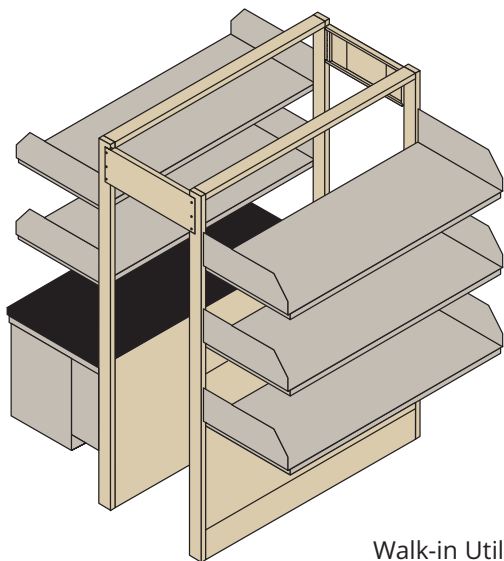

Walk-in Utility

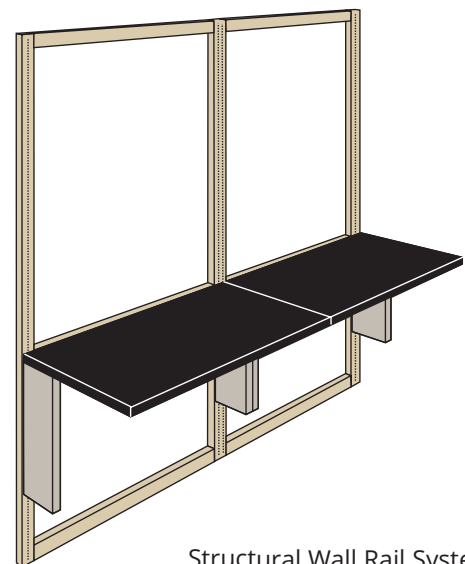

Structural Wall Rail System

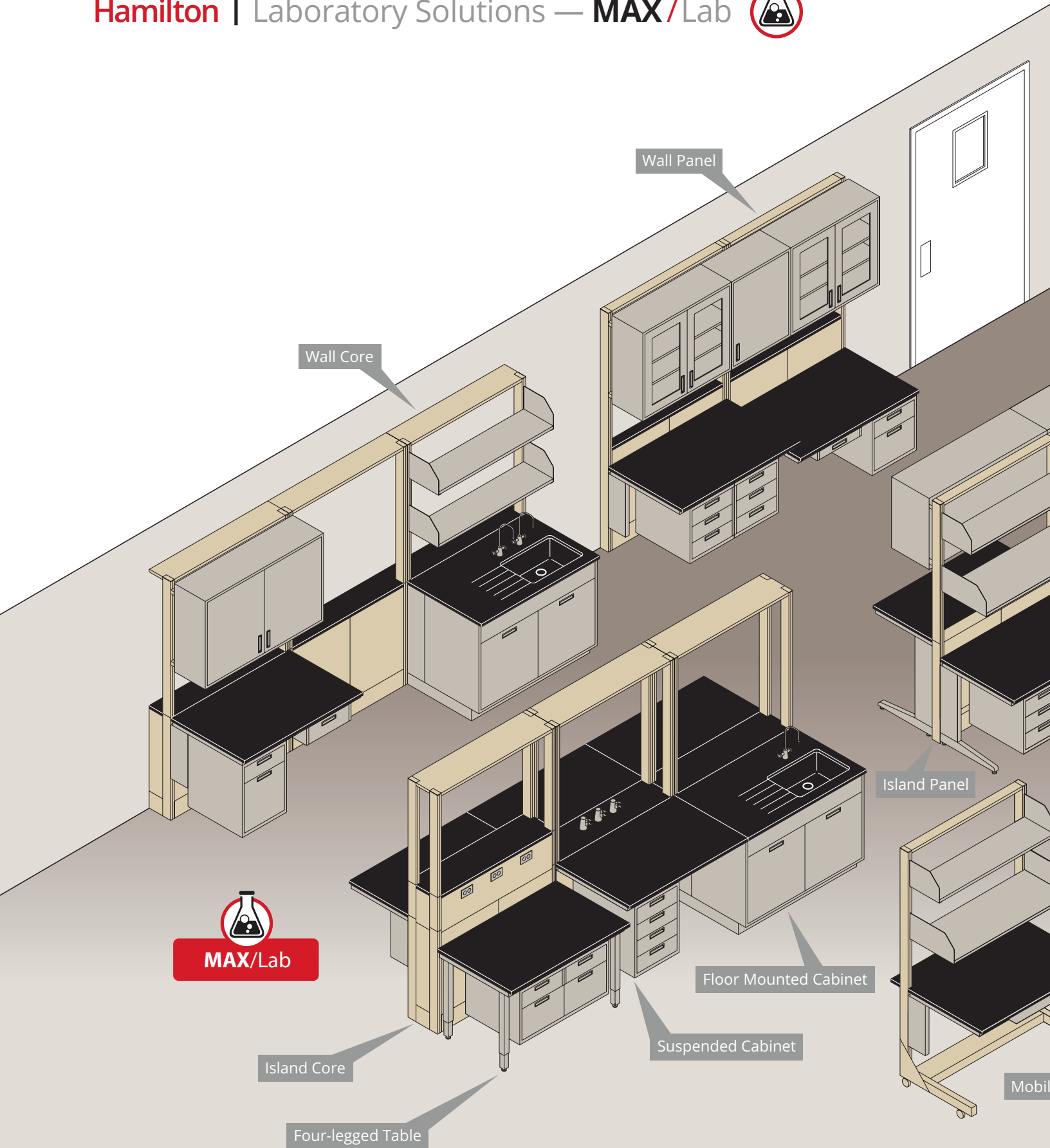





Wall Rail

Wall Rail

Benchtop Uprights

e Cart



## Maximum Mobility

The **MAX/Mobile** system was developed for labs where change is the only constant.

**MAX/Mobile** components are designed to minimize structural connections and floor penetrations for service delivery while providing the look and function of a more permanent laboratory workstation. Mobile products connect to overhead and vertical service carriers and docking stations using quick connects/disconnects to maximize function and flexibility.

Overhead service carriers are height adjustable and can accommodate storage shelves. Mobile transporters and workstations are designed to accommodate shelves, cable management and suspended cabinets, and can hold up to 2,600-pound loads. Mobile cabinets can double as an auxiliary work surface.





## Design Flexibility

**MAX**/Mobile system components can be used to create laboratories with the same functionality as floor mounted systems, but without the permanence.

Overhead service carriers and floor mounted docking stations allow for necessary equipment movement with no loss of functionality.

A full spectrum of **MAX** storage components is available to configure workstations to meet specific needs.



Whether in combination with floor mounted casework or as a complete mobile environment, **MAX**/Mobile components are designed to be moved quickly and economically yet provide a look of permanence.





## **Modular** Workstation Assemblies

Utilize free-standing modular structures to support work surfaces and storage components. Facilitate easy disassembly and reconfiguration with assemblies that are not built-in or attached to the building structure. A wide variety of **MAX** support structures and components are available to create workstations for the laboratory on the move.

## **Mobile** Cabinets

Enhance overall flexibility with **MAX**/Mobile cabinets featuring modular work surfaces. The units can be parked under cantilever table frames to duplicate the functionality of fixed casework and be easily relocated to provide knee or equipment space or facilitate floor cleaning.

Use Mobile cabinets to quickly expand work surface space, for transporting or sharing supplies and instruments.



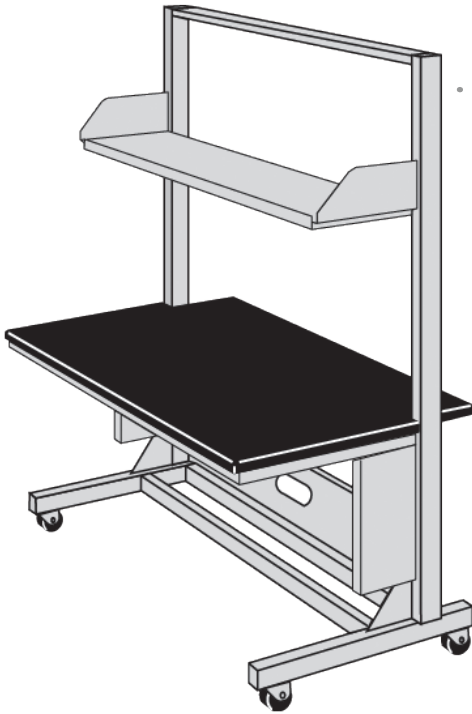

## MAX Power Bench

Complete your lab with an adjustable height, mobile laboratory workstation that provides instant height adjustment within a 12" range. The smooth, fluid motion of the PowerBench lift mechanism is ideal for sensitive instrumentation. Optional upper shelving and suspended storage cabinets provide storage capacity. Casters with retractable levels provide the ability to relocate the workstation instantly and firmly lock it in place.

## Service Delivery Modules

One key to optimizing the fixed footprint in a laboratory is to reduce or concentrate the floor penetration space of service lines. Service delivery modules are available in both over-head and floor-mounted configurations. Overhead service carriers move services overhead to free up floor space. Floor-mounted docking stations concentrate service lines in a small area and are ideal for use with transporters.



## Transporters



### Integrated Mobility/Adaptability

- Trends dictate that labs must be reconfigured quickly with minimal downtime and construction
- Lab layouts are changing to allow for interactive research plug-and-play

Mobile workstation units with the same storage capacity and functionality as casework, tables, equipment racks and specialized mobile platforms. Transporters facilitate rapid rearrangement of room layout and are ideal for sharing and servicing lab instruments and equipment.

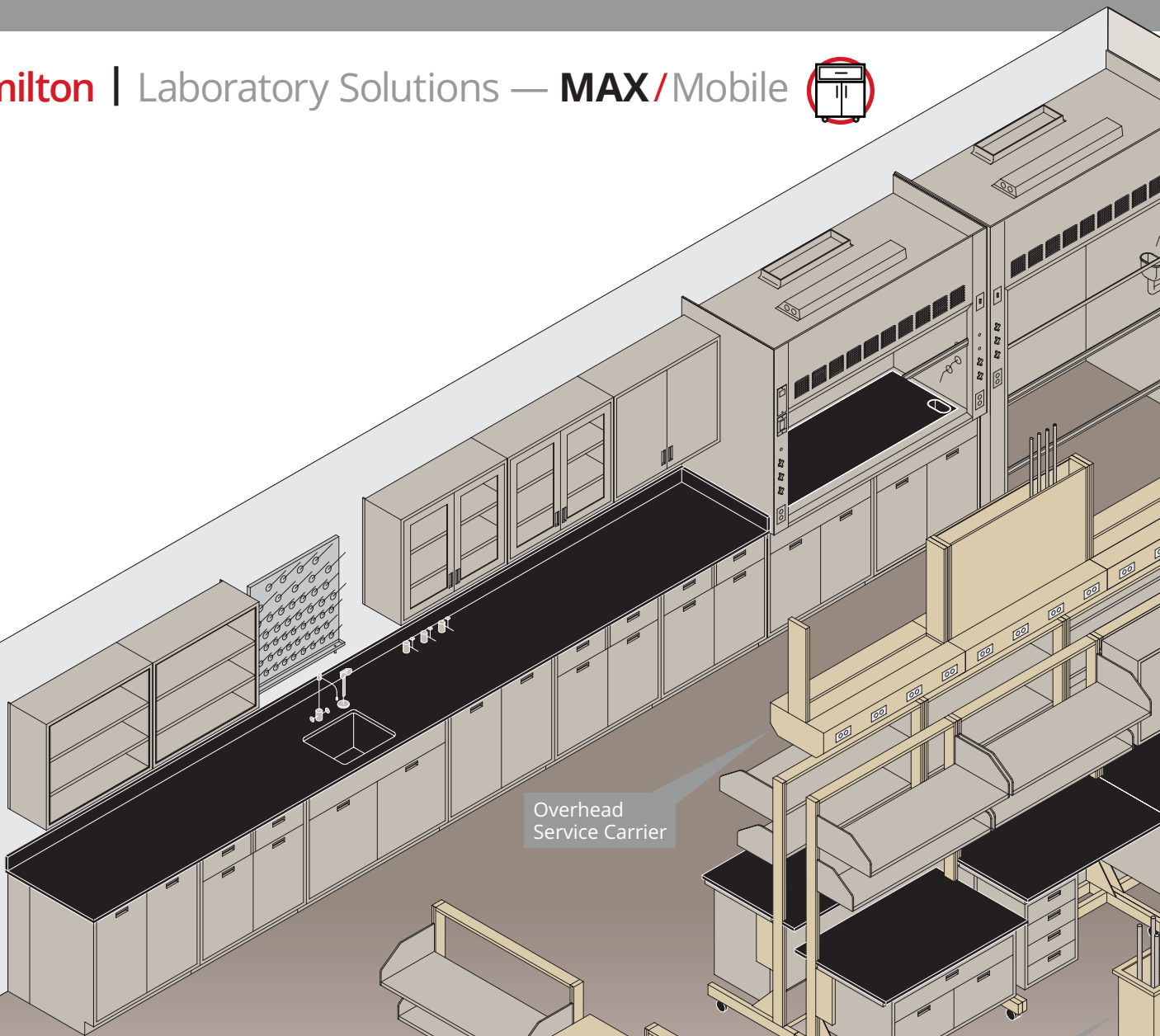

Overhead Service Carrier

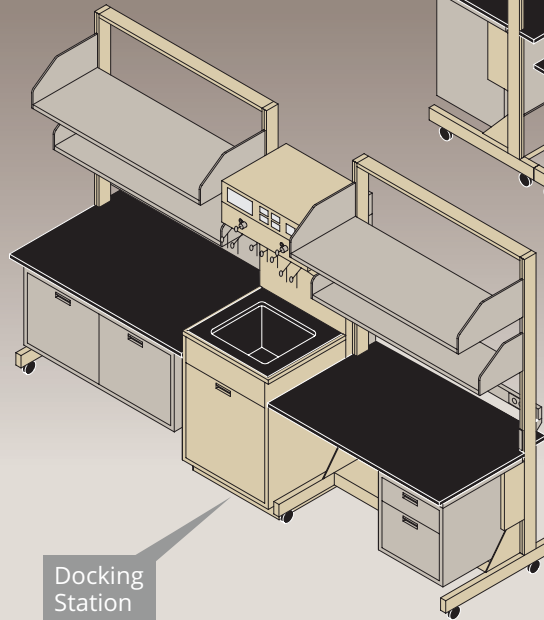

Docking Station

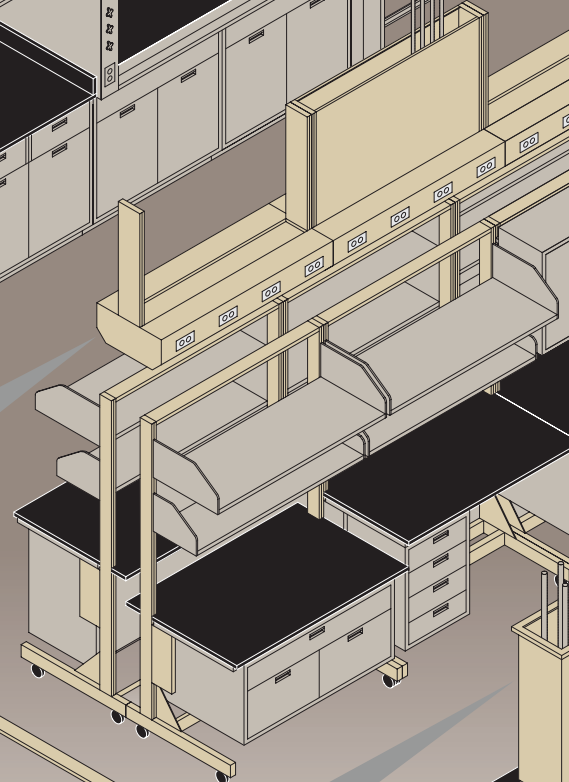

Vertical Overhead Service Carrier

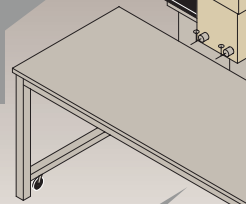

Robotics Table

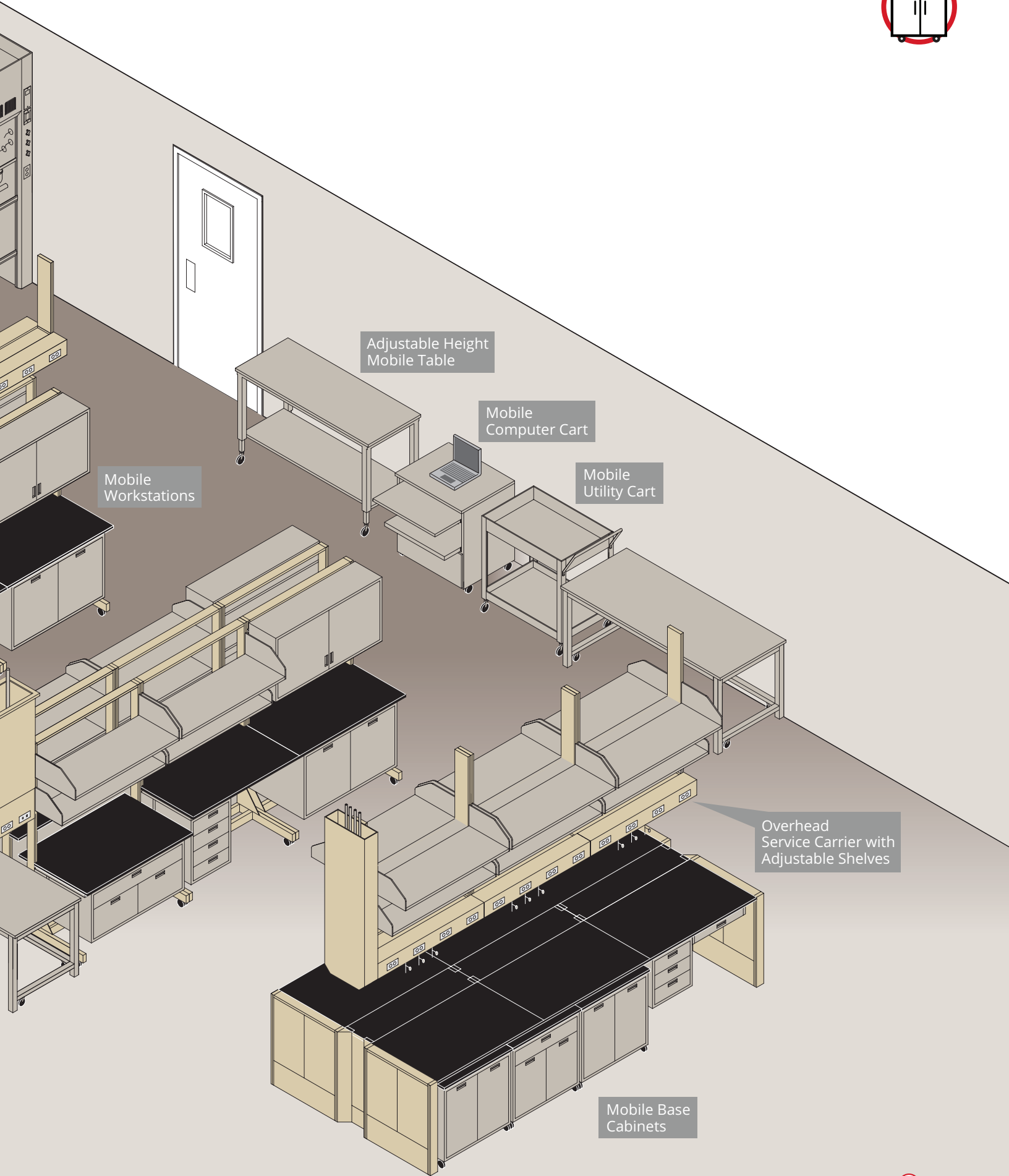

Mobile Workstations

Adjustable Height Mobile Table

Mobile Computer Cart

Mobile Utility Cart

Overhead Service Carrier with Adjustable Shelves

Mobile Base Cabinets





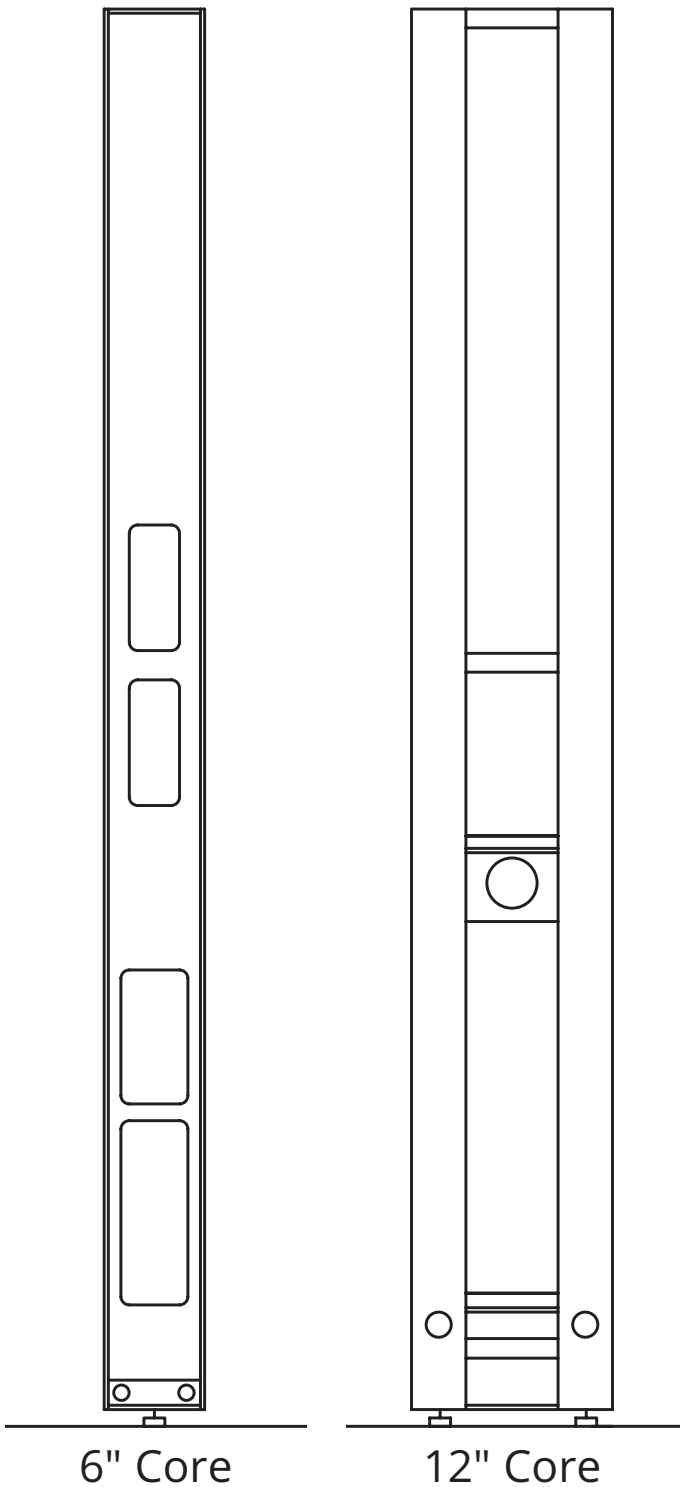

At half the width of typical core frames, **MAX/Wall** offers unmatched space efficiency



## Modular Structures

Used to create fully enclosed rooms, **MAX/Wall** provides floor-to-ceiling separation in laboratory workspaces.

- The versatile walls can be supported by incorporating:
  - Floor-mounted base cabinets
  - Extending walls to the ceiling
  - Integrating with other Hamilton **MAX/Wall** frames
- Moveable utility walls divide space with inset panels
- Walls feature a high degree of acoustical privacy
- Seamlessly incorporate walls with numerous **MAX** System components and accessories
- Based on the laboratory function:
  - Choose from various size panels
  - Select from assorted surface treatments
- Environmentally responsible and sustainable, **MAX/Wall** is reconfigurable without experiencing the disorder, time and cost of remodeling





**UCLA Medical Center -  
Telepathology International Lab**

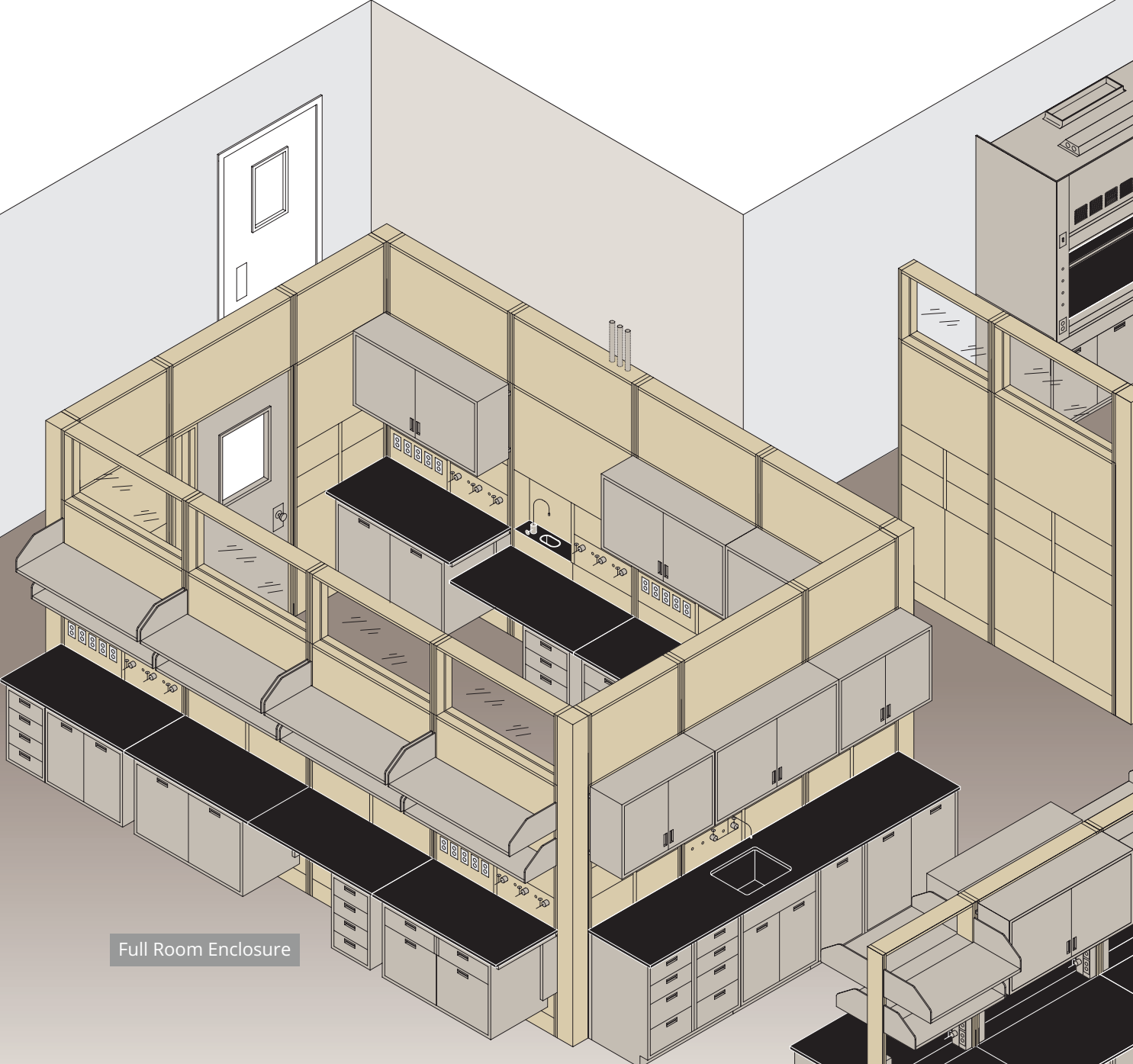

Full Room Enclosure



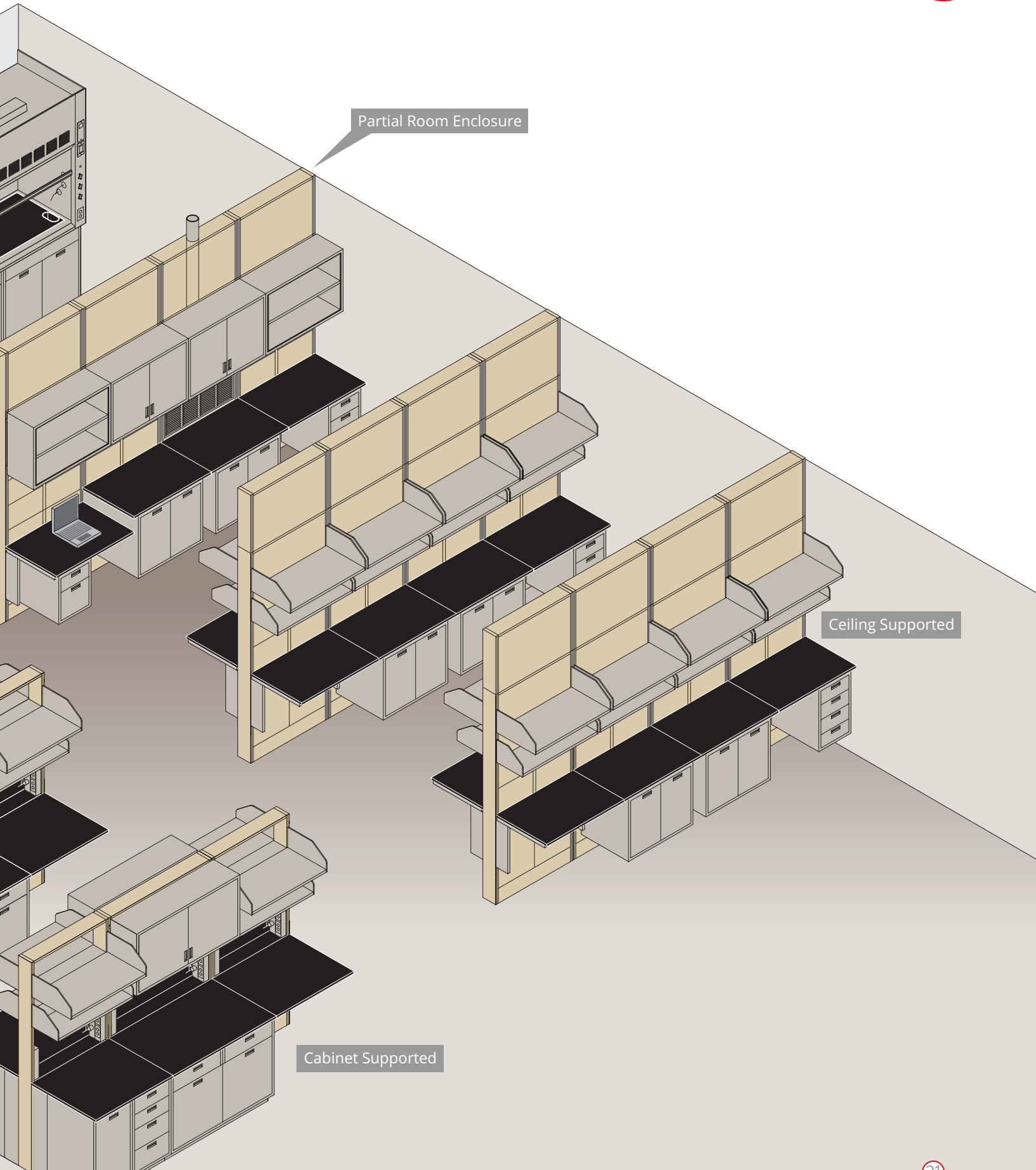

Partial Room Enclosure

Ceiling Supported

Cabinet Supported

## Furniture Solutions for the Dynamic Laboratory

The Hamilton **MAX** System adapts to changes in work processes and personnel. Ease of adjustability and minimal downtime are its most prominent features.

Benefits of using modular, easily movable workstation components include the following:

- Reusable components reduce cost and downtime
- Components can be moved to adapt to changing personnel, equipment and processes
- Responses to ADA accessibility needs are prompt and effective
- Increased user comfort can result in increased productivity
- Easy access to service lines reduces installation and maintenance time and cost
- Structural connections and floor penetrations for service delivery are minimized and reduce costs
- Total cost of ownership is reduced over the life of the laboratory
- The owners' return on investment is maximized



**MAX/Lab** increases productivity by providing height adjustable storage units, shelving, and work surfaces. Sitting height, standing height and wheelchair accessibility is featured.



A complete line of above-and-below counter storage components is available



Height adjustability of upper shelves in 1" increments

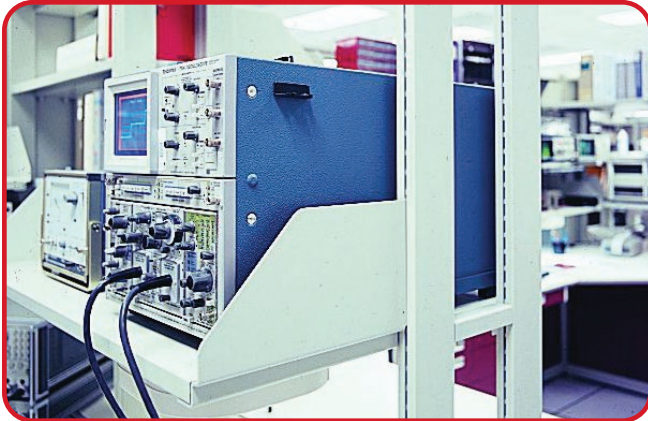

A **MAX/Lab** exclusive. Create a shelf that is up to 60" deep by combining one center and two out-side shelves at the same level. Slotted double uprights support work surfaces, cabinets, shelves, and accessories



Coved horizontal corners make drawers easier to keep clean

## Panorama Cabinet Styles

.....



Inset steel door and drawer fronts



Flush overlay with steel door and drawer fronts





**HAMILTON LABORATORY  
SOLUTIONS — U.S.**

825 East Albert Drive  
Manitowoc, WI 4  
Phone: 920-657-1970  
websales@hamiltonlab.com

**HAMILTON LABORATORY  
SOLUTIONS CO., LTD. — CHINA**

Rm. 510, Bld 2, 59 Shennan Rd.  
Shanghai, China 201108  
Phone: +86-21-5429-2605

