

UPRIGHT KIT FOR MOBILE HEIGHT ADJUSTABLE TABLE

KIT INCLUDES:

ITEM	DESCRIPTION	QTY
1	UPRIGHT	1
2	UPRIGHT CLAMP	2
3	INSIDE CLAMP	2
4	3/8 LOCKWASHER	8
5	3/8 X 1 1/2 HEX BOLT	4
6	3/8 X 1 BUTTON BOLT	4
7	1/4 X 1 FLAT SCREW	2
8	1/4 KEPS NUT	2

TOOLS REQUIRED:

PHILLIPS SCREWDRIVER
 SOCKET SET
 ALLEN WRENCH SET
 STANDARD WRENCH SET

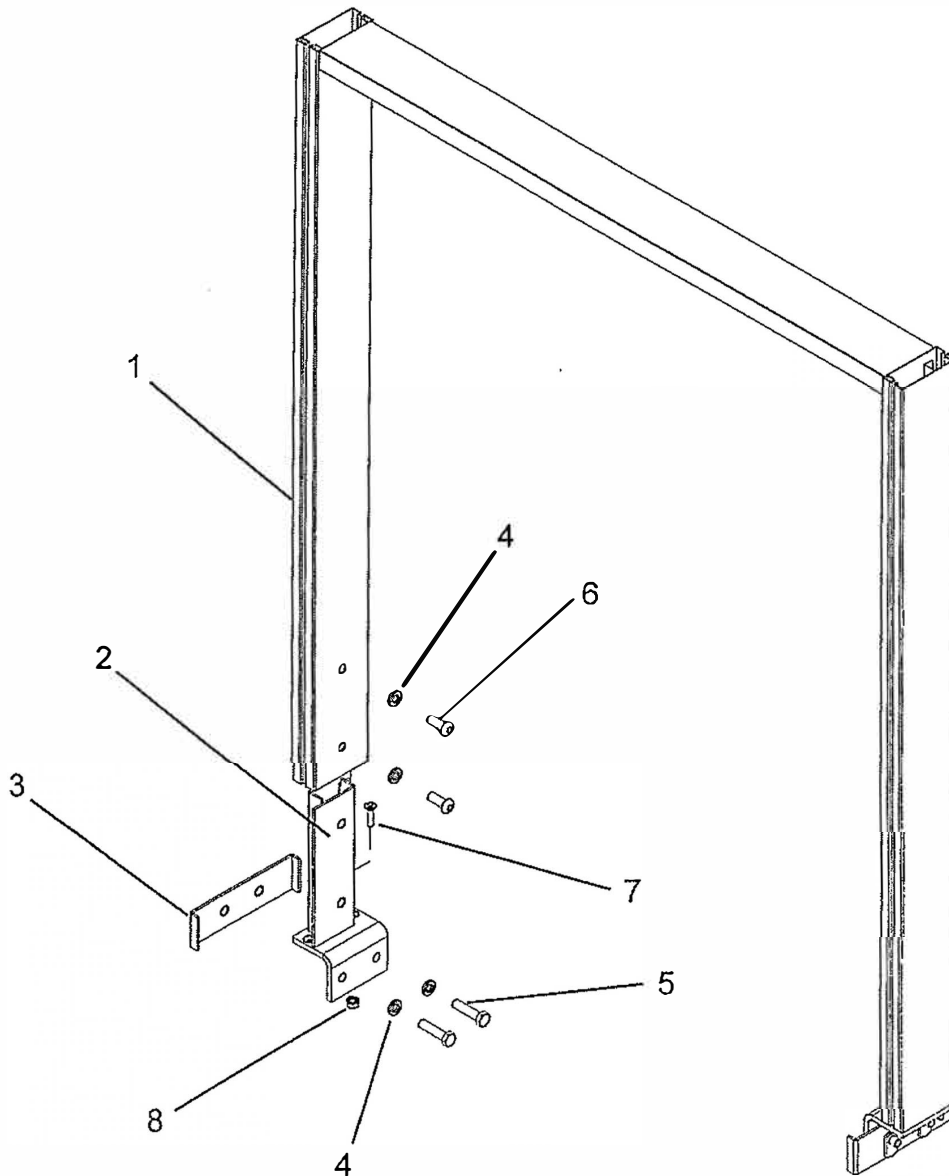

1. REMOVE CAP FROM REAR OF CART
SIDE RAIL.

2. SLIDE ITEM 3 (INSIDE CLAMP)
INTO SIDE RAIL WITH FLANGES AS SHOWN.

3. SET ITEM 2 (UPRIGHT CLAMP)
ON SIDE RAIL WITH BENT FLANGE TO INSIDE
AS SHOWN.

4. INSERT 3/8 X 1 1/2 HEX BOLTS AND
LOCKWASHERS THROUGH ITEM 2 AND
FASTEN INTO ITEM 3. DO NOT TIGHTEN.

5. ALIGN HOLE IN TOP OF ITEM 2 WITH
HOLE IN SIDE RAIL.

6. INSERT 1/4 X 1 FLATHEAD SCREW
THROUGH HOLE.

7. ATTACH 1/4 KEPS NUT TO SCREW.

8. TIGHTEN ALL FASTENERS.

9. REPEAT STEPS 1-8 FOR OTHER SIDE.

10. INSTALL THE TOP.

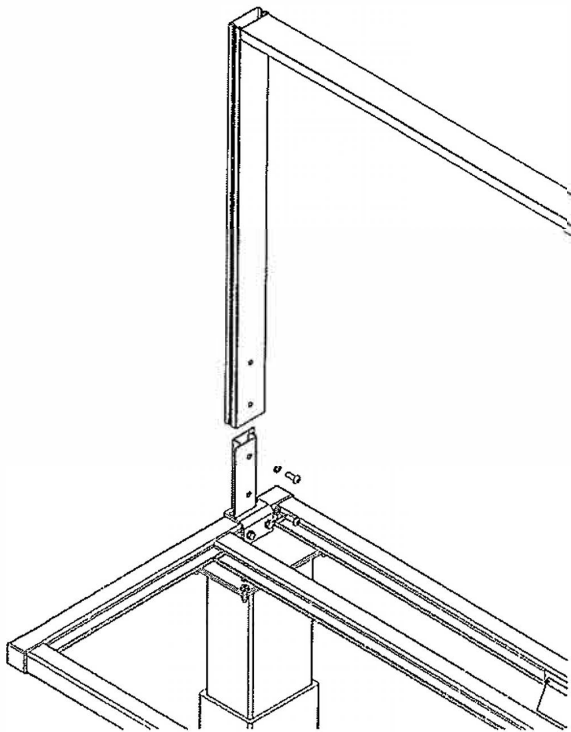
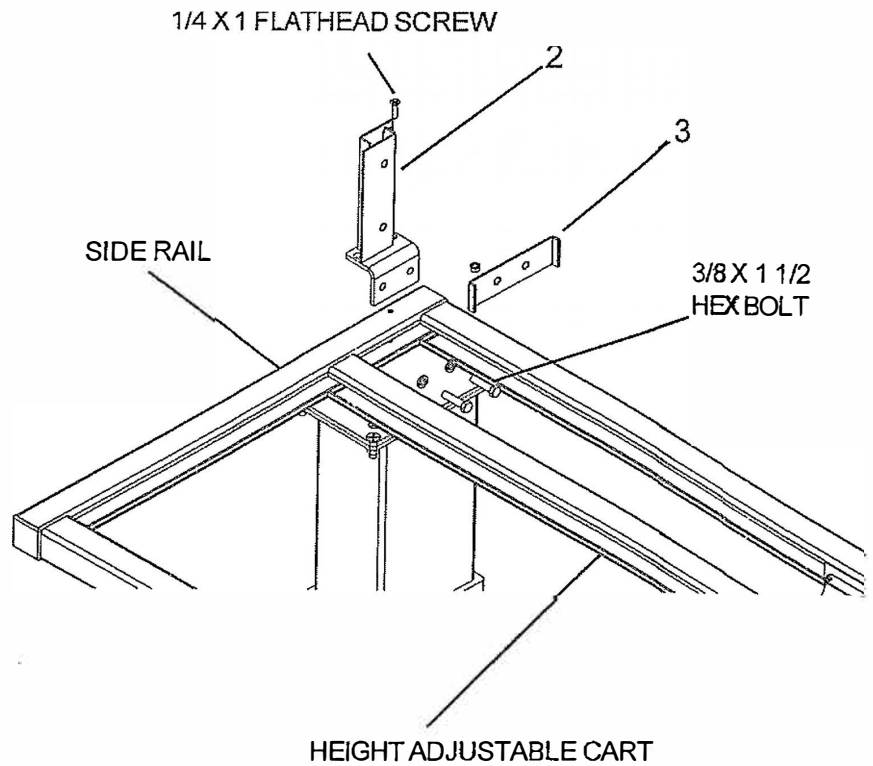

10. SLIDE UPRIGHT OVER UPRIGHT CLAMP.

11. INSERT 3/8 X 1 BUTTON SCREWS AND
LOCKWASHERS.

12. TIGHTEN ALL FASTENERS.

UPRIGHT KIT FOR MOBILE HEIGHT ADJUSTABLE TABLE

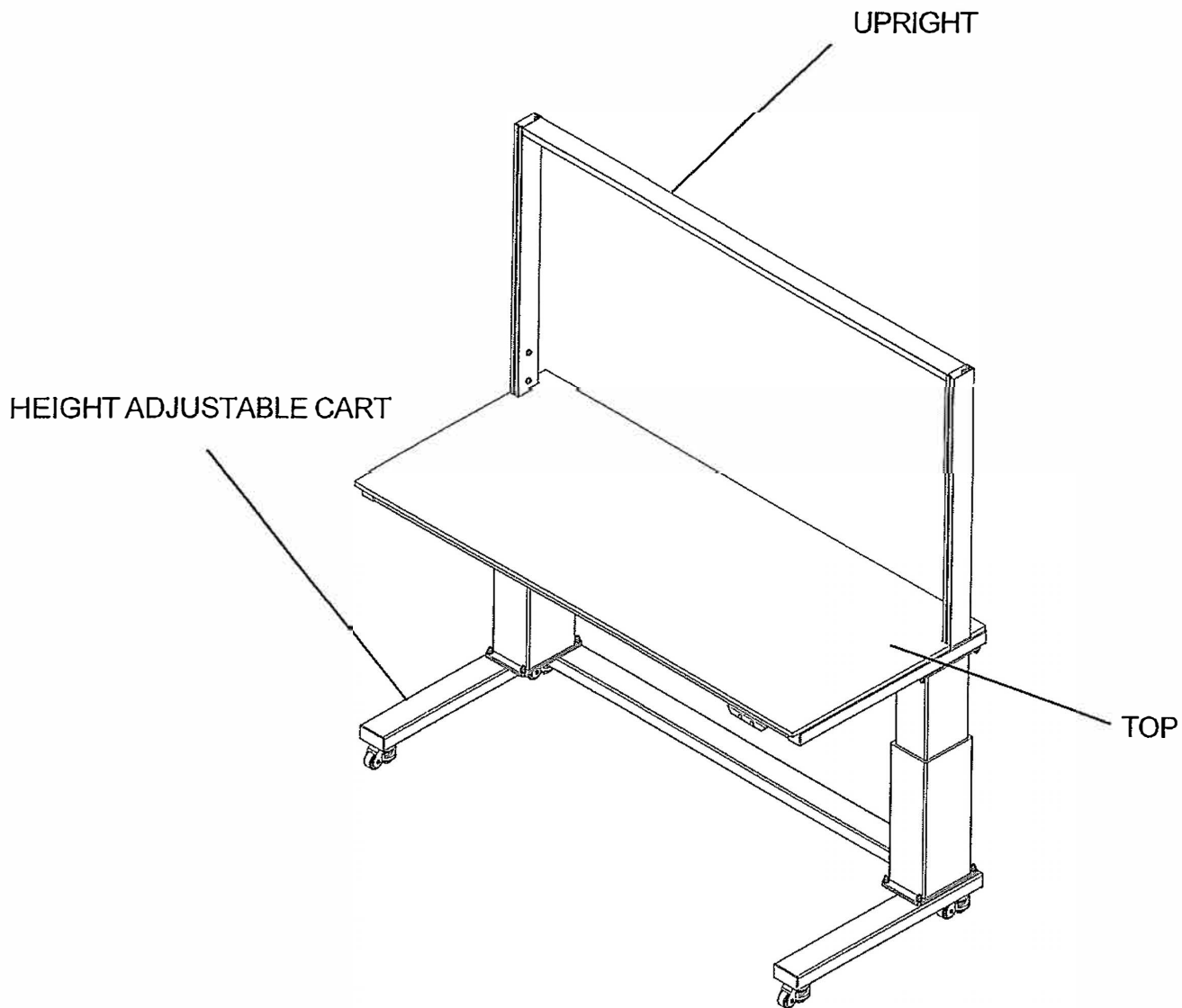

ASSEMBLED UNIT