

# Hamilton Pioneer Fume Hoods

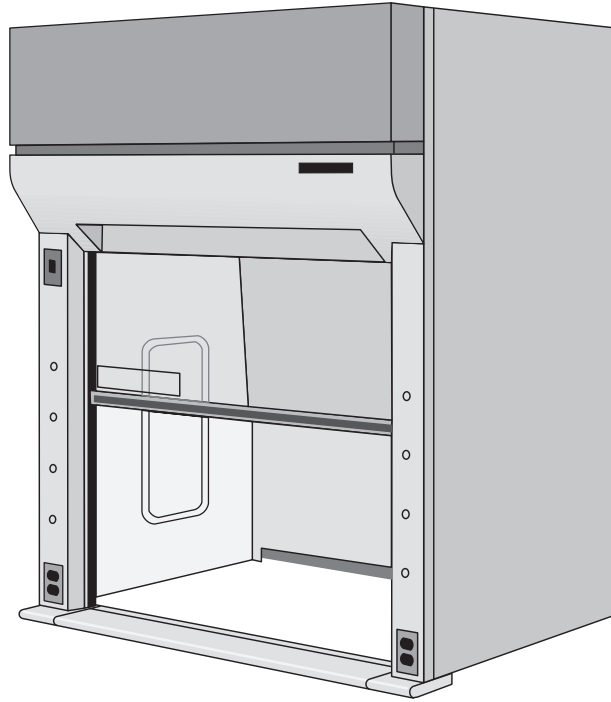

**Operation, Maintenance and Installation Instructions**



Introduction ..... 2

Fume Hood Identification ..... 3

Warning and Operating Instructions..... 4

Installation ..... 5-10

    Fume Hood Superstructure Installation..... 5-6

    Two Piece Fixed Baffle Installation ..... 6-7

    Setting Up and Adjusting the Supply-Air Switch..... 7

    Side Enclosure Panel Installation..... 8

    Sash Cover and Ceiling Front Enclosure Installation ..... 8

    Ceiling Side and Rear Enclosures Installation ..... 8

    Installing Filler Panel onto Ceiling Front Enclosure ..... 9

    Fume Hood Monitors..... 9

    Exhaust Filter Installation ..... 10

    Minihelic Gauge Installation ..... 10

Maintenance And Adjustments ..... 11-19

    General Maintenance ..... 11

    Fume Hood Inspection ..... 11

    Cleaning Fume Hood Interiors..... 11

    Directed-Air System Blower Inspection ..... 12

    Fluorescent Light Tube Replacement ..... 12

    Access Panel Gasket Removal ..... 12

    Access Panel Gasket Installation..... 12

    Access Through Front Posts ..... 13

    Roller Chain Replacement ..... 13

    Top-hung Combination Sash Glass Replacement ..... 14

    Top-hung Combination Sash Roller Replacement..... 15

    Unframed Sash Glass Replacement..... 16

    Glass Header Panel Replacement ..... 17

    Autosash Adjustment and Replacement..... 17

    Operation of the Sash Monitor and Directed-Air Monitoring System ..... 18

    Blower RPM Adjustments ..... 18

    Monitoring Exhaust Filters Using a Manometer Assembly ..... 19

Fume Hood Testing..... 20-22

Troubleshooting ..... 22-23

Dimensions are nominal, and illustrations and specifications are based on the latest product information available at the time of publication. The right is reserved to make changes at any time without notice.

Fume hoods are exposed to extremes of temperature, reagent fumes and working surface abuse. Regular care will prolong service life and insure safe working conditions.

The exhaust system and blower of a fume hood must function properly for safety. Maintenance personnel should service the fan and motor assembly regularly, lubricate as required, and make sure that the exhaust system is free from obstructions. Semiannually, accumulated deposits should be removed from the impeller blade and housing.

A simple test with lighted match or smoke will show if the air is being drawn into the hood. More accurate checks of air velocity can be made with a thermal anemometer. See Inspection and Field Evaluation procedure.

Always place equipment and apparatus as far back into the fume hood as possible since this provides greater assurance of proper fume collection and removal.

Large, bulky apparatus or equipment should be placed in the fume hood to permit air flow around it, and never placed so as to interfere with the operation of the baffle system. Raise large items an inch or two above work surface. Spilled liquids, acids, or corrosive materials should be immediately wiped up and the surface neutralized with water or the proper neutralizing agent so as to prevent damage to the work surface and the hood interior or to apparatus and equipment installed in the hood.

### **Special fume hoods are required for the handling of Perchloric Acid.**

1. Turn on interior light for proper illumination of working area. Note the operating instruction plate above switch.
2. Verify that exhaust system is operating properly before starting fume producing activities within hood.
3. Install burners, water baths, hot plates, set-ups and apparatus as far back in hood as possible for safety and optimum performance.
4. Laminated safety glass sash is designed to be used as a safety shield. Move sash to lowest position that provides proper access and carry out manipulations with sash protecting head and upper body.
5. Limit fume hood use to those activities which can be performed safely. Substitute safety cabinets or glove boxes as safety dictates.

This Product was not evaluated for use with Perchloric Acid or Radioisotopes by UL

Never use the hood as a storage case for the accumulation of apparatus and equipment, and do not allow containers of corrosive acids and volatile materials to remain in the hood for long periods of time.

When hot plates or water baths are installed in the hood and are being used, adjust the baffles so that the heat and fumes are properly exhausted. Remember, the fume hood is a safety device. In case the exhaust system fails while in use, shut off all services and accessories and immediately leave the area of the fume hood. In all cases, lower the sash completely.

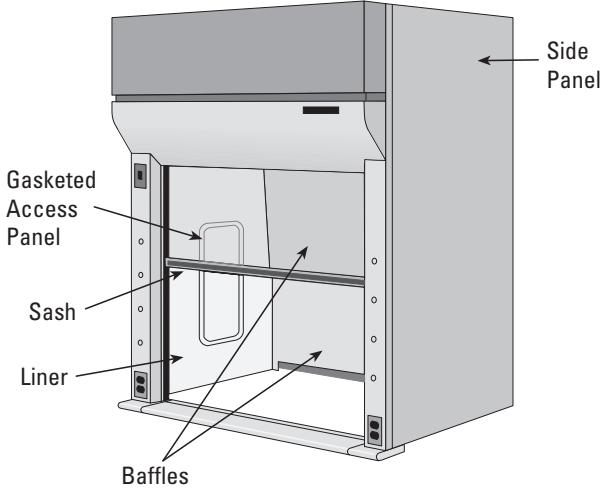

## Warning

This product is intended for use with certain chemicals that can cause serious injury or illness through inhalation or physical contact. While this product is intended to minimize exposure to certain hazardous chemicals when selected, installed and operated properly, its performance and the safety of the user is affected by a number of factors. These include the HVAC system, the specific chemicals and processes being used, proper operation and the condition of the room.

Before using this fume hood, consult the owner's industrial hygienist or safety representative to make sure:

- 1) The specific fume hood alarms, controls and the HVAC system have been properly selected and are operating correctly;
- 2) The hood has been tested after installation and routinely thereafter to ensure the fume hood is providing the proper containment for the specific chemicals and processes being used;
- 3) There has been appropriate training on the correct use of the fume hood and handling of the specific chemicals and the fume hood operating instructions have been reviewed;
- 4) Any personal protective devices that are required are properly selected and provided;
- 5) The fume hood is being operated at the appropriate face velocity. The fume hood should never be operated with the sash in the full open position.

2. This fume hood is not intended to be used with all chemicals or all chemical processes. Consult the owner's industrial hygienist or safety representative to determine whether the hood is appropriate for the chemicals and processes to be used.
3. Verify that the fume hood exhaust system and controls are operating properly and providing the necessary air flow. If in doubt, the owner's industrial hygienist or safety representative should be consulted. It is recommended that the hood be equipped with an air flow monitoring device. Before using the fume hood, verify that the monitor is operating properly by testing the monitor.
4. The hood should not be operated with the sash in the full open (set-up) position. When the hood is in use, the opening of the sash glass should be kept at a minimum. On a vertical rising sash, the sash glass should be no higher than 18". Horizontal sliding panels on combination sashes must be closed when sash is raised vertically. The sash should remain closed when the hood is not in use.
5. Place chemicals and other work materials at least six (6) inches inside the sash.
6. Do not restrict air flow inside the hood. Do not put large items in front of the baffles. Large apparatus should be elevated on blocks. Remove all materials not needed for the immediate work. The hood must not be used for storage purposes.
7. Never place your head inside the hood.
8. External air movement can affect the performance of the hood. Do not operate near open doors, open windows or fans. Avoid rapid body movements. Do not open the hood if there are cross-drafts or turbulence in front of the hood. Do not open the sash rapidly.
9. If this hood is equipped with adjustable baffles, do not adjust the baffles without consulting the owner's industrial hygienist or safety representative.
10. Wear gloves and other protective clothing if contact with contaminants is a hazard.
11. Clean spills immediately.
12. If fumes or odors are present, stop operating the hood, close the sash and contact the owner's industrial hygienist or safety representative immediately.
13. It is recommended that this fume hood be tested and certified annually by the owner according to applicable industry and government standards.

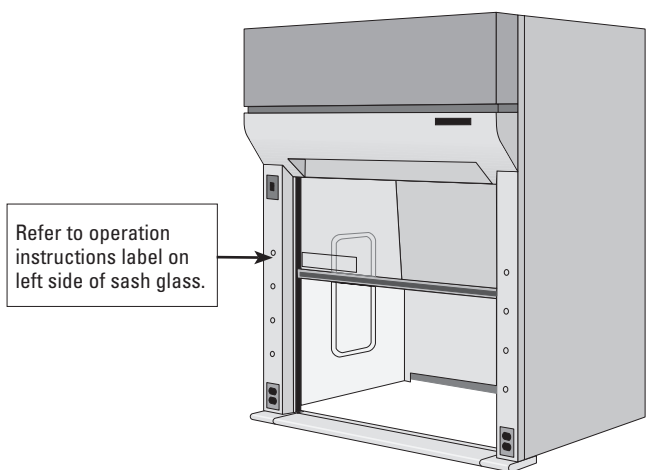

## Operating Instructions

**Failure to follow these instructions could result in physical injury or illness.**

**Caution: Do not use hood for perchloric acid procedures.**

1. Do not use this fume hood unless you have received proper training from the owner's industrial hygienist or safety representative.

Concept™, Pioneer™, AutoSash™,  
Directed AirflowTechnology™

**Fume Hood Superstructure Installation**

1. Remove screws from sash hold-down clips. Open the sash and remove blocking, being careful not to damage sill or baffles.

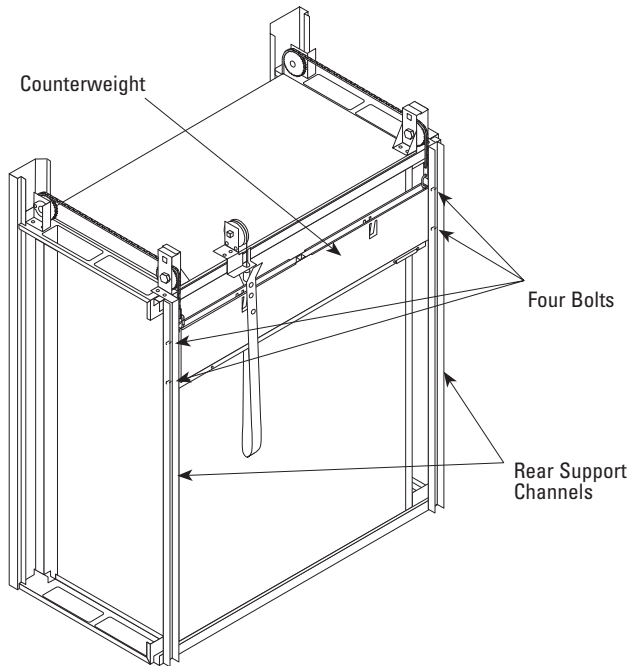

**Figure 1**

2. Release counterweight by removing four bolts that secure the counterweight to the rear support channels.
3. Remove tape securing fixed glass panel.

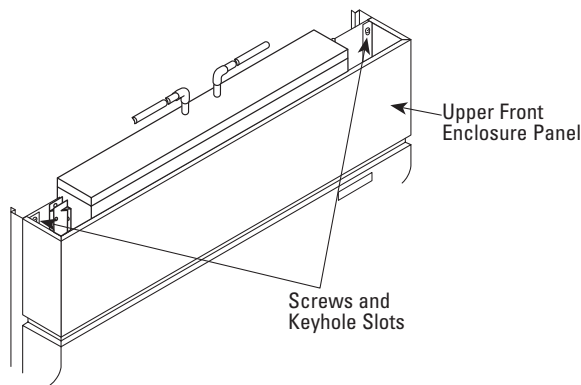

**Figure 2**

4. Loosen but do not remove screws securing upper front enclosure panel to superstructure.
5. Remove shipping screws holding the fume hood frame to the skid. Save four (4) of these screws, No. 10 x 5/8", to secure hood to the work surface. Check to verify the work surface is level.
6. Place the fume hood on the work surface taking care to protect the work surface. The superstructure must be plumb, square and level before proceeding.

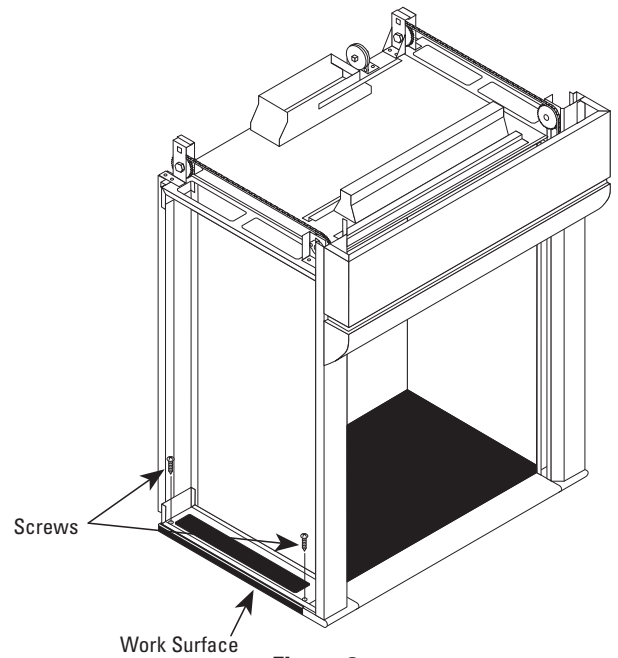

**Figure 3**

7. Drill two (2) each 1/8" diameter pilot holes at each side structural frame into the work surface and secure same with four (4) No. 10 x 5/8" screws saved from the shipping skid.
8. Caulk hood to work surface with silicone sealant.
9. Check the following items:
  - The counterweight operates free of obstructions.
  - There is proper horizontal sash alignment and counterweight balance.
  - The sash does not bind in the sash guides.
10. Baffles can be installed at this time. See page 7.

Fume Hood Superstructure Installation – continued

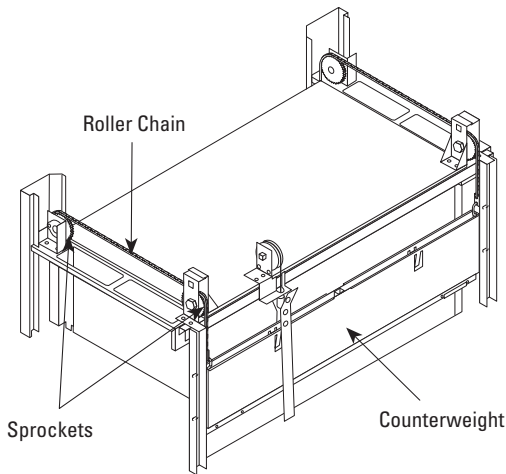

Figure 4

11. Check alignment of roller chain with sprockets.
12. Check counterweight balance and unrestricted movement. The sash and counterweight are balanced at the factory. Small amounts of weight can be added or removed from the weight pan if necessary for fine tuning in the field.

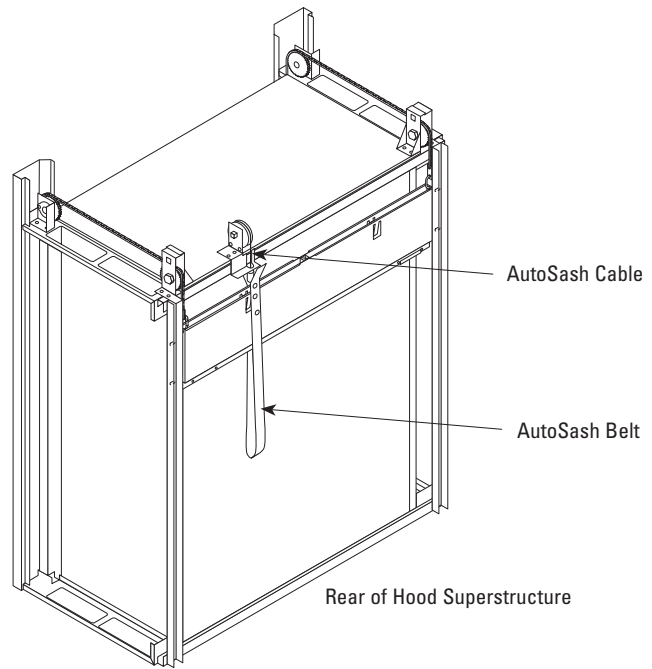

Figure 6

15. Check that AutoSash belt and cable have unrestricted movement.
16. Check sash travel for unrestricted movement.

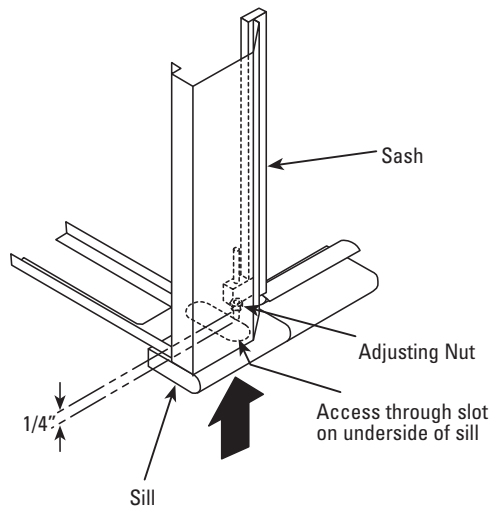

Figure 5

13. Level sash by adjusting the two nuts (one at each corner post) securing the roller chains to the sash. Nuts are accessible from beneath the hood, reaching through the large slot on the underside of the sill. Threaded shank should protrude past leveling nut a minimum of 1/4" after adjustment.
14. Check sash travel for unrestricted movement.



**Two-Piece Fixed Baffle Installation**

1. Place paper screen on top of upper support brackets.
2. Place top baffle into position by engaging top edge into lip of the three ceiling blocks. Lift and lock baffle into top side of Upper Support Brackets.
3. Place bottom baffle into position. Place top edge of baffle into the forward slot of the Upper Support Bracket. Lift and lock baffle into lower support brackets.

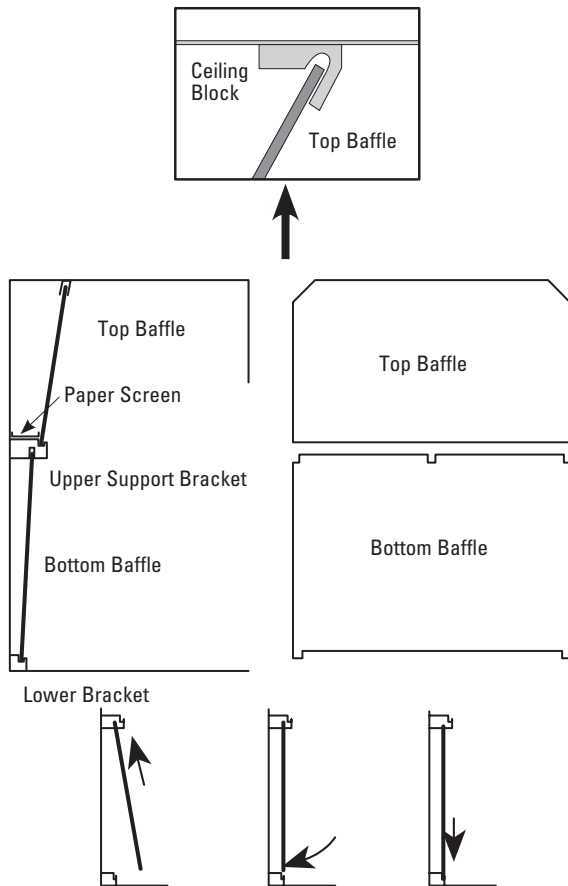

**Figure 7**

**Setting Up and Adjusting Supply-Air Pressure Switch**

1. Connect to the power system, and activate the Directed-Air System blower by raising the sash above an 18-inch opening.

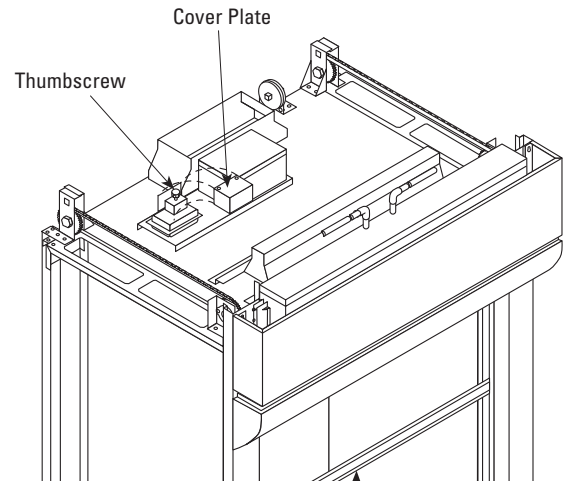

**Figure 8**

2. Locate the pressure switch on the roof of the hood, in the left rear corner. Open the cover plate on top of the pressure switch to expose the adjustment thumbscrew.

**Refer to *Operation of the Sash and Directed-Air Monitoring System* on page 18 for definition of alarm conditions.**

**If the Directed-Air System failure alarm is sounding, turn the adjustment thumbscrew counter-clockwise until the alarm silences. Then turn the adjustment screw an additional 1/2 turn counter-clockwise. Note that the adjustment can't be made rapidly, as the system needs a few seconds to stabilize after the adjustment is made.**

**If the directed-Air System alarm is not sounding, turn the adjustment screw clockwise until it just sounds, then adjust it back a 1/2 turn counter-clockwise.**

3. Check the adjustment by covering the inlet on both sides of the Directed-Air System blower. The alarm should sound.

**Caution: The blower wheels are rotating rapidly. Do not let any object enter the blower inlets.**

4. Close the cover plate on the pressure switch to complete the set-up adjustment.

**Side Enclosure Panel Installation**

1. Lower the side panel into the side frame of the fume hood, engaging the frame's lower lip.
2. While pressing down on the two black catches, rotate the side panel and engage the frame's upper lip. Gently apply additional pressure to the panel and release the catches to secure the panel to the hood.

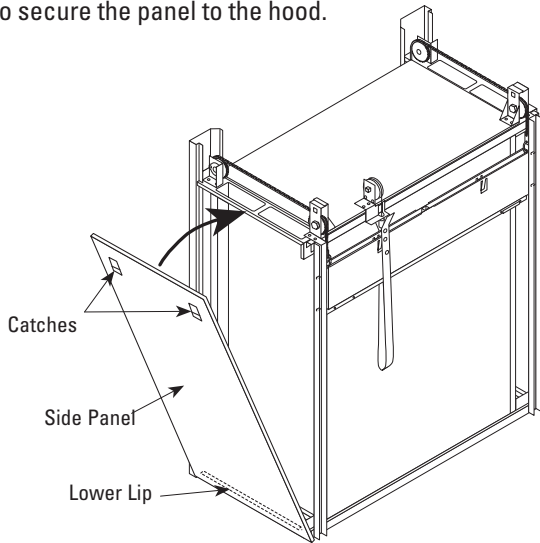

**Figure 9**

**Sash Cover and Ceiling Front Enclosure Installation**

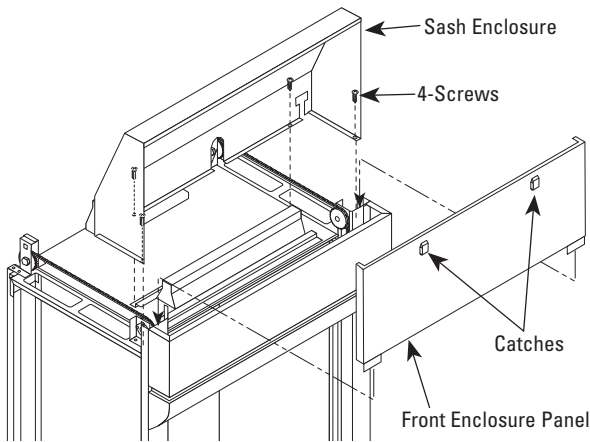
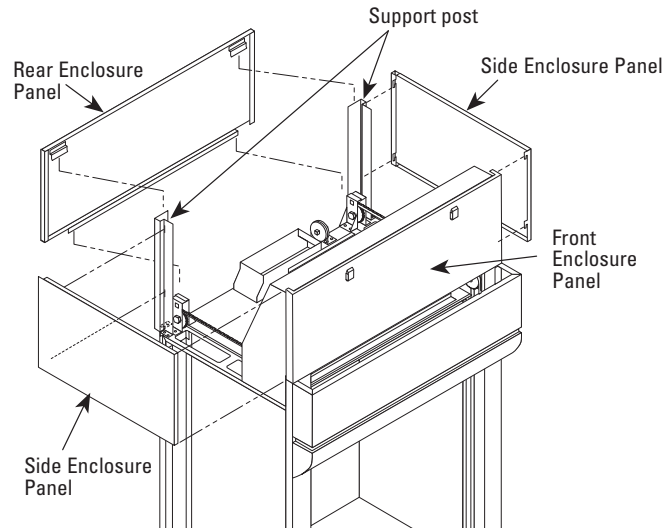

**Figure 10**

1. Place sash enclosure on top of hood, routing roller chains and lamp wiring through the appropriate openings in enclosure.
2. Fasten sash enclosure to top of hood with four screws.
3. Raise front enclosure panel to top of hood and engage the bottom lip of front enclosure panel into the top edge of the hood's corner posts.
4. While pressing down on the two black catches, rotate the front panel to engage the sash cover's upper lip. Gently apply additional pressure to the front panel and release the catches to secure the front panel to the sash cover.

**Ceiling Side and Rear Enclosure Panel Installation**

**Enclosure panels are designed for below ceiling grid installations only – see below**



**Figure 11**

1. Fasten support post to rear corner of the top of the hood.
2. Hang ceiling side enclosure panel onto sash cover/front enclosure panel assembly and support post.
3. Hang ceiling rear enclosure panel onto support posts.

### Installing Filler Panel onto Ceiling Front Enclosure

Enclosure panels are designed for below ceiling grid installations only – see below

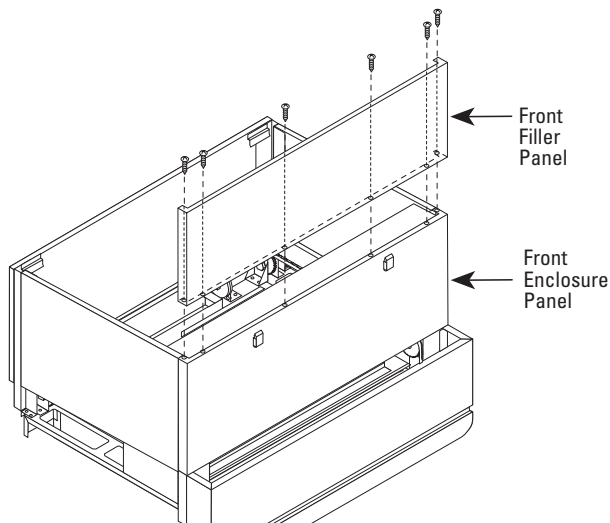

Figure 12

1. Position filler panel on top of ceiling front enclosure so that front and side surfaces are flush.
2. Drive screws through the holes in filler panel flange, into top flange of ceiling enclosure.

**Installation Information:** *With suspended ceilings, it is suggested that the enclosure assembly extend to the bottom of the ceiling. The hung ceiling should extend over the top of the hood and be trimmed around the mechanical connections to ensure proper room pressure control of the HVAC system.*

### Fume Hood Monitor

#### Models 54LFA0500 and 54LFA1000

Proper fume hood operation is key to laboratory safety, comfort and energy management. OSHA requires that laboratories take measures to ensure proper and adequate operation of fume hoods. Recommendations include the use of a continuous air monitoring device. The ANSI Z9.5 and NFPA 45 standards reinforce these requirements.

Fume hood monitors have the ability to monitor true fume hood face velocity using thermal sensors located in the instrument. The thermal sensors are exposed to clean laboratory air only. They can be surface-mounted in minutes eliminating the need for expensive panel cutouts.

Each model is equipped with indicator lights that illuminate based on a predetermined set-point. An audible 85dB piezoelectric alarm sounds and a red indicator light illuminates to warn of potentially dangerous low air flow conditions.

Fume hood monitors are shipped with operation manuals.

#### ■ 54LFA0500

- Low flow set point
- Audible and visual alarm
- I/O options

#### ■ 54LFA1000

- Analog meter
- Audible and visual alarm
- I/O control

***A fume hood face velocity monitor is required on all Pioneer fume hoods.***

Hamilton fume hood monitors are shipped with operating instructions.

**Exhaust Filter Installation**

**Product Numbers 54L29600, 54L29700, 54L29800 and 54L29900**

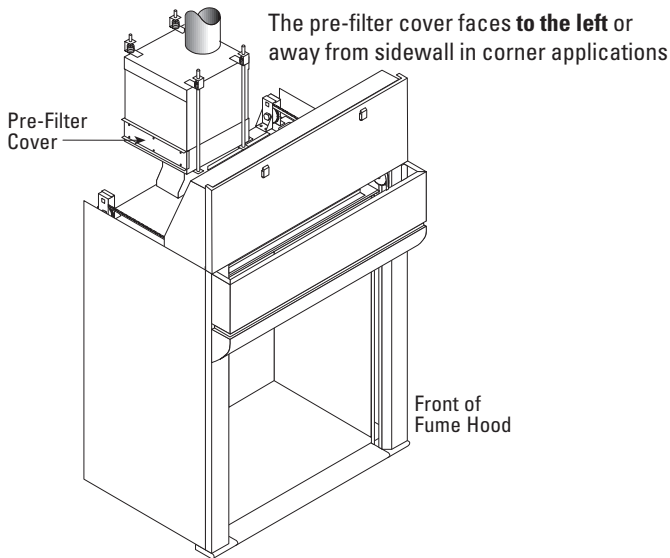

**Figure 14**

Securely attach the filter inlet collar to hood exhaust transition using same method as followed in the duct system. Filter outlet may be attached to duct using flexible connector or same as inlet connection.

**Minihelic Gauge Installation**

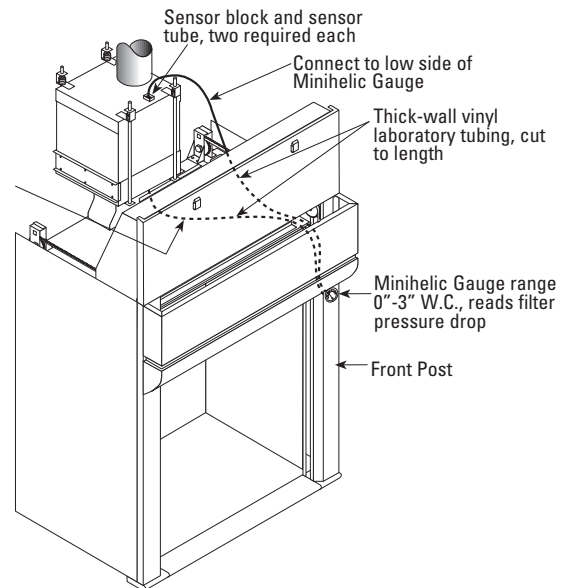

**Figure 15**

Replacement filter sets consist of one rough and one HEPA filter.

Product Number 54L30200 – Filter set for 54L29600 or 54L29800.

Product Number 54L30000 – Filter set for 54L29700 or 54L29900.

### General Maintenance of Fume Hoods

Fume hood maintenance procedures consist primarily of clean-up, adjustment, lubrication, and replacement of worn, damaged or nonfunctioning parts. Lubrication of sash guides, chains, pulley wheels, and other working parts should be accomplished as required and replacement of broken, worn, or non-functioning parts as needed. The following items should be **inspected and serviced at least semi-annually**:

- Inspect liner and baffles for condition and cleanliness.
- Inspect low air flow detectors.
- Inspect service fixtures and lights.
- Inspect pulleys and belts.
- Check sash operation and chain routing including a complete visual check of the entire system.
- Lubricate roller chain and sprockets.
- Check for wear on AutoSash cable and belt.
- Rotate airfoil upwind spill containment trough for cleaning.
- Check for obstructions on paper screen located behind top baffle; see baffle installation.
- Check for obstructions at the two inlets to the blower on the Directed-Air System chamber; see Inspecting Supply Air Blower.
- Check black monitor tape on left side of sash glass every six months. Replace tape when signs of peeling or wear-through exist.
- Check velocity and pressure sensing detectors.
- Check flow alarms, both visual and audible signals.
- Check signal transmission for alarms designed to activate signals at more than one location.
- Conduct instrument verification of fume hood face velocity and determination of usage by observation and interview.
- Inspect ductwork and blower.

Clean-up should be accomplished by, or under the supervision of, a knowledgeable technician and should include removal of all baffles and clean-up of all interior surfaces.

Flush all spills immediately using neutralizing compounds as required and clean thoroughly. Use good housekeeping in laboratory fume hoods at all times.

### Fume Hood Inspection Procedures

Safety considerations recommend that a schedule of inspection and documentation be set up for every laboratory fume hood at least annually.

An inspection record should be maintained. This record may be in the form of a label attached to the fume hood, or a log held by the laboratory director or health safety director.

Inspection procedures should include instrument verification of fume hood face velocity and a determination of usage by observation and interview. These procedures should also consist of a physical examination of liner condition and cleanliness, baffle and sash operation and condition, chains and sprockets, light operation and condition, and service fixture function.

Inspection results should be recorded and reported to the proper authority for any required action.

Low air flow detectors should be inspected at least annually. Where extreme hazardous or corrosive conditions exist or when filters are present in the system, the inspection frequency should be increased appropriately.

Velocity and pressure sensing detectors should be tested at each inspection. Low-flow or no-flow alarms of the visible (lights) or audible (horns or bells) type should be tested for correct operation at least at each inspection. Signal transmission for alarms designed to activate signals at more than one location should be verified at each location during each inspection. Frayed or broken items should be replaced promptly.

### Cleaning Fume Hood Interiors

Fume hood liners are maintained by an occasional washdown with detergent and warm water. Stains and salt deposits can be removed with a weak acid solution (5%) or an appropriate solvent – **DO NOT USE ACETONE**. Remove baffles for access to all surfaces.

**Directed-Air System Blower Inspection**

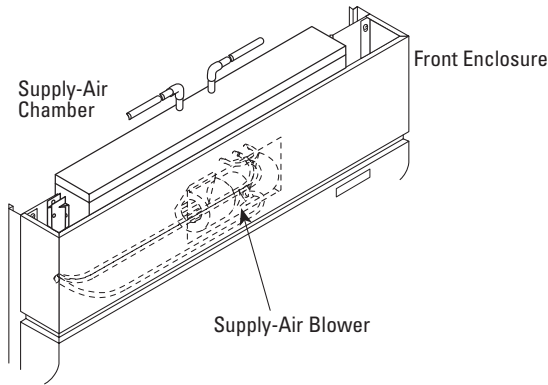

**Figure 16**

1. Fully close sash so that the Directed-Air blower turns off.
2. Remove upper half of the front enclosure by raising it upward so as to disengage from the two screws at the keyhole slots.
3. Confirm the blower wheels are not rotating before inspecting the blower inlets for obstructions.
4. Reverse Steps 1 and 2 to return hood to usable condition.

**Flourescent Light Tube Replacement**

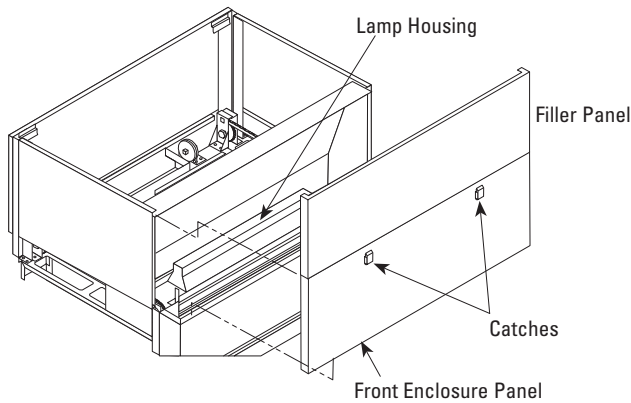
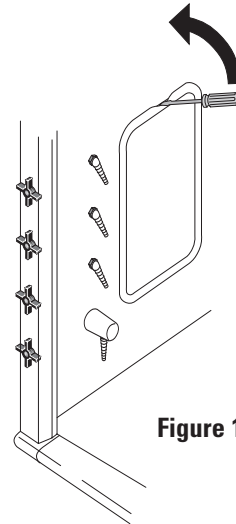

**Figure 17**

1. Flip hood light switch to OFF position.
2. While pressing down on the two black latches, rotate the ceiling front enclosure panel forward to disengage from the sash's upper lip.
3. Raise the ceiling front enclosure panel to disengage the bottom lip of the panel from the top of the hood's corner posts.
4. Squeeze bottom edge of lamp housing to disengage from galvanized channel. Rotate lamp housing up to expose tubes. Replace tubes with similar type as in unit. Turn light switch ON to verify connections.
5. Reverse Steps 1 thru 3 to return hood to usable condition.

**Access Panel Gasket Removal**

Insert screwdriver and wedge out panel and gasket assembly.



**Figure 18**

**Access Panel Gasket Installation**

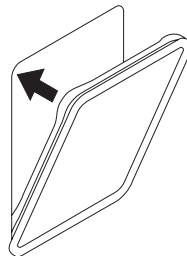

**Figure 19**

Twist the corners of gasket towards cutout before insertion. Replace the panel and work the entire periphery of the gasket to be sure that the gasket is completely snapped into position. Gasket should be smooth and tight when properly seated.

Replace all caulk/sealant that was removed during disassembly.

The fixtures used within fume hoods are needle valve type, and if they wear, stainless steel cone and seat replacement kits can be ordered from Hamilton Laboratory Solutions. It is necessary to remove the handle from the valve and then remove the valve mechanism. This can be done through the access panels (See Figure 19) if fixtures are mounted in the superstructure, or from inside the cupboard if the fixtures are deck mounted.

Access to the valves by removal of the exterior end panels (Page 8) permits seat replacement without the need to remove the valve. This approach is recommended when ends are exposed and accessible.

Access to service fixture valves on fume hoods without access panels is obtained by removal of the exterior end panels (Page 8) when hoods are free-standing.

Access Through Front Posts

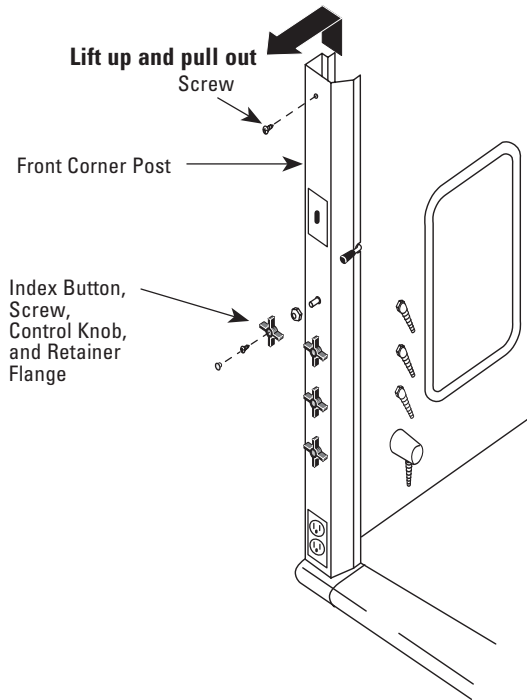

Figure 20

When ends are not accessible, access is gained through the front posts. Remove both upper and lower halves of front enclosure panel, unscrew index button, control knob, and retainer flange from fixture handle rod. Remove screw from post as shown above, tilt outward and lift up to remove post. Electrical fixtures are connected to post with flexible conduit and can remain attached.

Roller Chain Replacement

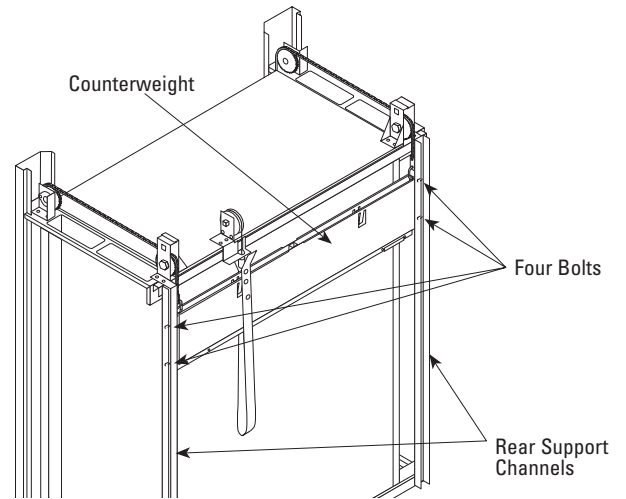

Figure 21

1. Lower the sash to the closed (down) position.
2. Secure the counterweight to the rear support channels with four bolts.

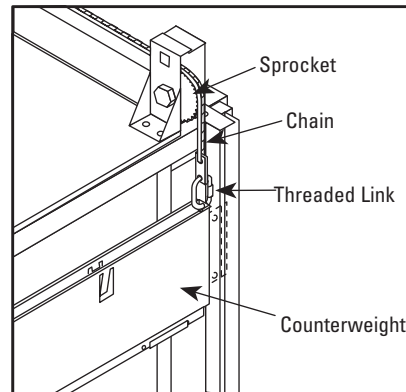

Figure 22

3. Detach the roller chain assembly from the counterweight by disconnecting the threaded link.
4. Detach the roller chain assembly from the sash by removing the leveling nut (See Figure 5), pull the chain upward and unthread from the sprockets.
5. Reverse the above steps to re-install the roller chain assembly, using care to apply tension to the roller chain as it is draped over the sprockets placing any slack at the rear most span (See Figure 4). Level sash after replacing the roller chain (See Figure 4).



Top-hung Combination Sash Glass Replacement

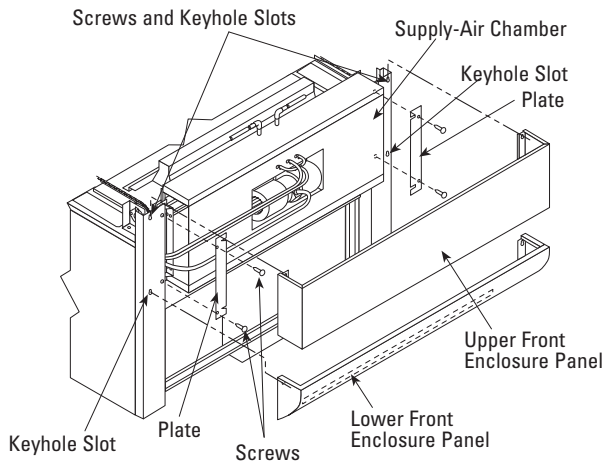

Figure 23

1. Remove upper half of the front enclosure by raising it upward to disengage from the screws at the keyhole slots.
2. Remove lower half of the front enclosure by removing two screws at the keyhole slots joining the corner posts, and then lowering the panel to disengage from the discharge of the Directed-Air System chamber.
3. Remove plate from left and right sides of Directed-Air System chamber by removing screws and caulk anchoring it to corner post.

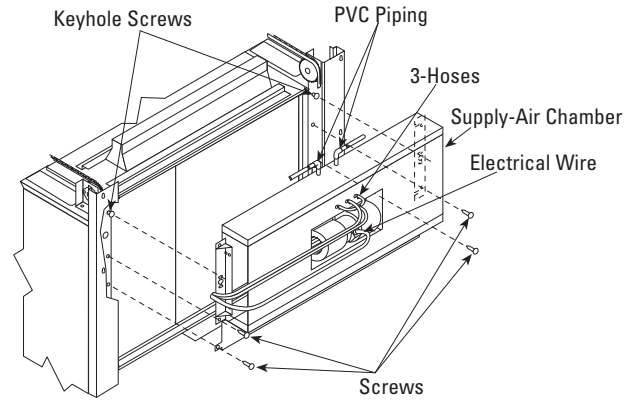

Figure 24

4. Disconnect three hoses from the barbed taps on front of Directed-Air System chamber.
5. **Caution: Shut OFF electrical power to hood and blower.** After confirming the power to the blower is shut off, disconnect the electrical wiring in the junction box on the blower motor.
6. Withdraw the PVC piping (if supplied) from the Directed-Air System chamber by pulling upward on the two segments that enter the top of the chamber.
7. Locate the three screws fastening the Directed-Air System chamber side brackets to each side of the hood frame. Remove the bottom two screws, while only loosening slightly the top keyhole screw.
8. Remove the Directed-Air System chamber by raising it upward to disengage from the two screws at the keyhole slots.
9. Clamp the front sprockets/shaft to prevent its rotation and to hold the sash in the closed (down) position.
10. Unclamp the sash glass pane from the horizontal sliders by removing the four bolts holding the clamp channel in place, see Figure 26.
11. Replace the double-sided tape before re-installing the glass pane into the clamp channel.
12. Reverse the above steps to return the hood to usable condition.
13. Replace all caulk/sealant that was removed during assembly.



## Top-hung Combination Sash Roller Replacement

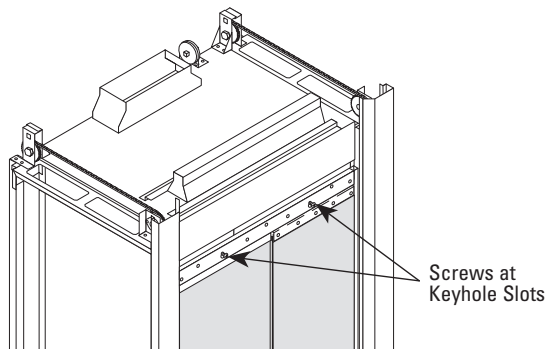

Figure 25

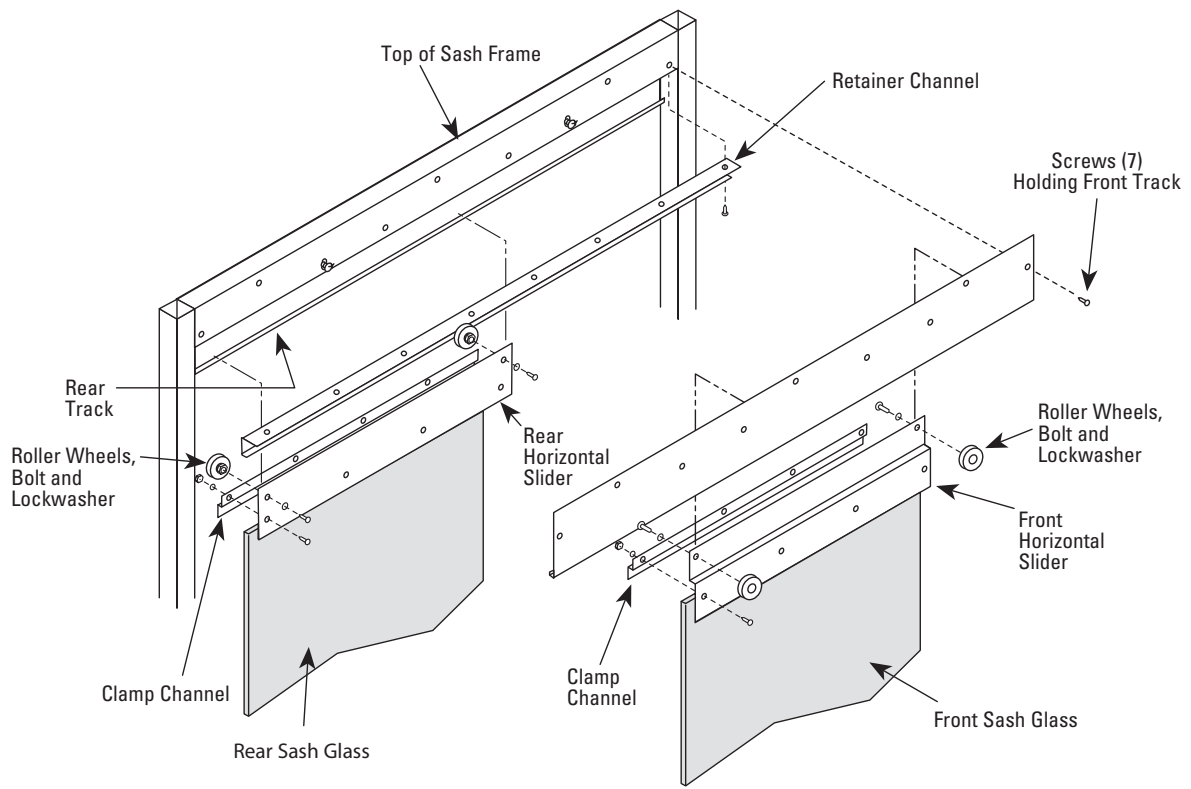

Figure 26

1. Refer to Steps 1 through 9 of *Top-hung Combination Sash Glass Replacement* on page 14.
2. Loosen but do not remove the two screws located at the two keyhole slots at the top of the sash frame as shown.
3. Remove the remaining seven screws from the top of the sash frame. Using care to support the horizontal sliders, lower the front track from the top sash frame.
4. Remove the front horizontal slider from the front track.
5. Remove the rear horizontal slider from the rear track.
6. Remove roller wheels as necessary by unfastening bolt and lockwasher as shown.
7. Replace roller wheels as necessary using bolt and lockwasher as shown.
8. Reverse the above steps to return the hood to usable condition.
9. Replace all caulk/sealant that was removed during assembly.

Unframed Sash Glass Replacement

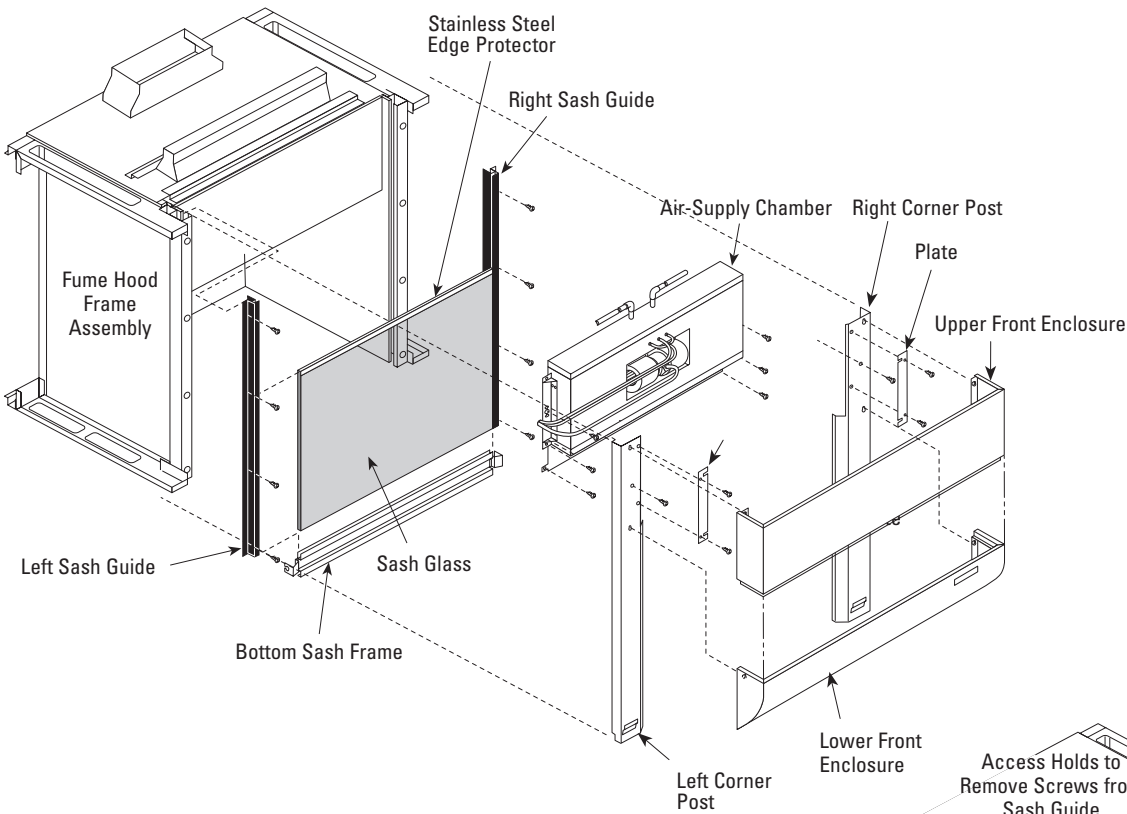

Figure 27

1. See instructions how to remove the Upper and Lower Front Enclosure Panels and the Supply-Air Chamber on page 13.
2. Clamp the front sprockets/shaft to prevent its rotation and to hold the sash in the closed (down) position.
3. Remove both front corner posts (See Figure 20).

**Refer to Figure 27 and 28**

4. Remove screws that hold the sash guide to the front frame upright and slide the guide up and away from the sash. **Care should be taken when the sash guide is removed so that the glass does not fall from the remaining guide.**
5. While holding the sash glass, first remove the upper stainless steel edge protector. Then force the glass from the bottom sash pull by pulling upward while holding the sash pull in place. At this point the glass and gasket material should come loose, the bottom sash frame remains attach to the chain and one sash guide.

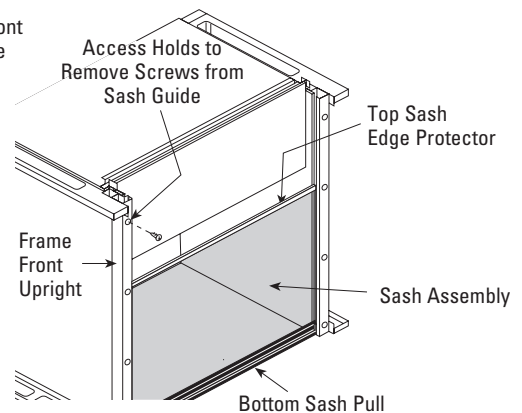

Figure 28

6. Place gasket material on the bottom of the new sash glass. Align with the bottom frame member and press into place. Replace the stainless steel edge protector on the top horizontal edge of the glass. Replace the sash guide and remove clamps holding the front sprockets and shelf. Move the sash up and down to test for proper alignment in the sash guides. If at this point you notice the glass is not completely seated into the bottom frame member, tap gently on the bottom with a rubber mallet to seat the glass.
7. Replace the front corner posts and upper and lower front enclosure panels.

**WARNING**

If chain is damaged, it MUST be replaced to avoid personal injury or damage to the fume hood.

Glass Header Panel Replacement

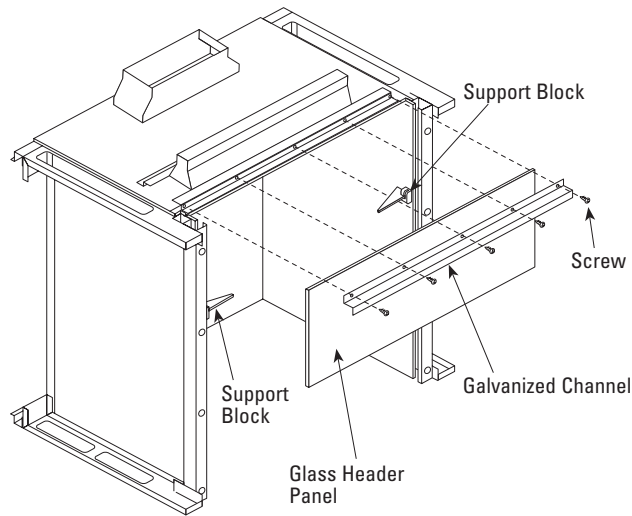

Figure 29

1. See instructions how to remove the Upper and Lower Front Enclosure Panels and the Supply-Air Chamber on page 14.
2. Locate the galvanized channel that clamps the top edge of the glass header panel to the hood. Remove the five screws that fasten the galvanized channel to the hood. **Caution: Support the glass panel to prevent it from tipping outward when channel is removed.**
3. Lift glass panel upward and out of the two support blocks at its lower corners.
4. Reverse the above steps to return the hood to a usable condition
5. Replace all caulk/sealant that was removed during disassembly.

Autosash Adjustment and Replacement

1. To access AutoSash belt for adjustment or replacement, remove two screws mounting assembly to top of hood.
2. If AutoSash fails to lower the sash below the desired point, shorten the belt loop by changing the belt's attachment point to the cable.
3. The AutoSash spring reel can be replaced. Remove one push-on nut from the square shaft and withdraw square shaft from spring reel hub.
4. When re-installing AutoSash assembly, the spring reel should be pre-tensioned, the cable routed through the guide slot, and the belt encircled around the counterweight before fastening the assembly to the top of the hood.

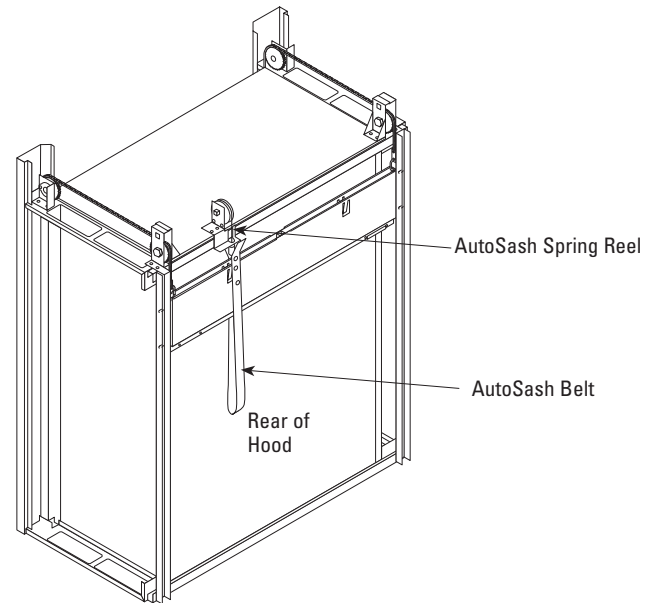
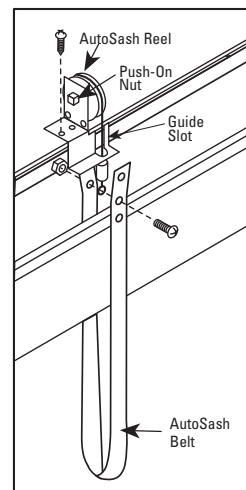

Figure 30



Operation of the Sash and Directed-Air Monitoring System

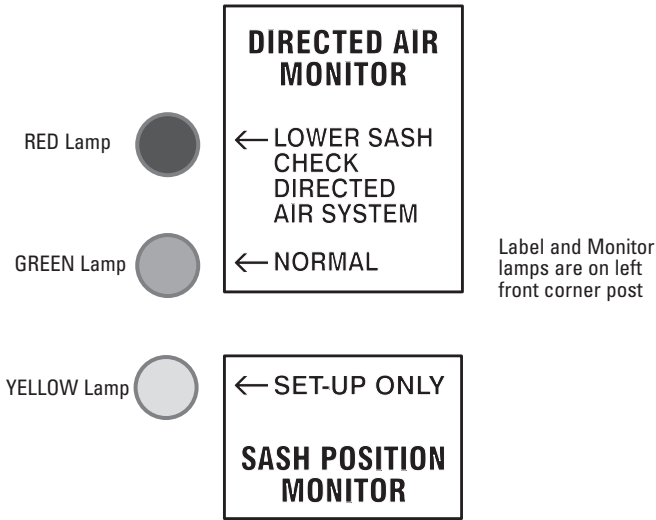
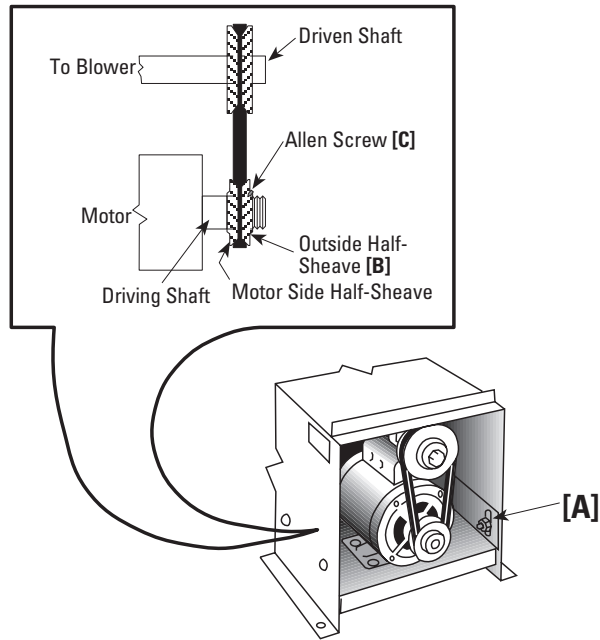

Figure 31

1. When the sash is positioned at an opening less than 18-inches, there will be no airflow from the Directed-Air System discharge. A GREEN light will indicate that the system is NORMAL. On combination Sash hoods, when the sash is between 1" and 18", the yellow light will flash, as a reminder to close the horizontal panels.
2. When the sash is raised above the operating mode position a YELLOW light on the left post will indicate SET UP ONLY, and a BEEP will be heard every ten seconds to remind the user that the sash is positioned for set-up/knock-down modes only. The YELLOW light will turn off or flash and the reminder BEEP will go silent when the sash is lowered to an operating mode position.
3. When the sash is positioned at an opening greater than 18-inches, a gentle flow of air will be directed downward from the discharge. A GREEN light will indicate that the system is still functioning normally.
4. If the Directed-Air System blower fails to operate properly, a RED light on the left post will indicate LOWER SASH AND CHECK DIRECTED-AIR SYSTEM. An alarm will sound once every second. The RED light will turn off and the alarm will go silent when the sash is lowered back to the operating position of less than 18-inches. **Caution: A qualified professional should inspect the Directed-Air System immediately. The fume hood should not be used until the problem is rectified.**

Blower RPM Adjustments

1. Remove housing over motor blower assembly.
2. Loosen the four (4) bolts [A] which hold the motor mounting plate stationary so that the plate has a vertical movement, as shown in illustration below. This should be done so that a later adjustment for correcting belt tension can be made.
3. Make all adjustments ONLY with the outside half sheave [B] on the driving shaft.
4. To increase the RPM of the blower, increase the diameter of the driving sheave by loosening the Allen screw [C] and turning the outside half-sheave toward the motor. Tightening the Allen screw to the flat portion of the threaded shaft then fixes the diameter of the sheave.
5. To decrease the RPM of the blower, decrease the diameter of the driving sheave by loosening the Allen screw [C] and turning the outside half-sheave away from the motor. Tightening the Allen screw to the flat portion of the threaded shaft then fixes the diameter of the sheave.
6. Correct belt tension (side play 1/2" to 3/4") can now be set by adjusting the loosened motor mounting plate and tightening the four (4) bolts.



**Sheave** = Pulley  
**Driven** = Attached to blower shaft  
**Driving** = Attached to motor shaft

**Monitoring Exhaust Filters Using a Manometer Assembly**

When a filter device is installed on a fume hood exhaust system, it is important that the filter performance and condition be monitored to ensure proper performance of the filter and of the fume hood to which it is connected.

By measuring the pressure drop across the filters, the manometer assembly will provide information on filter function and condition. Manometer reading with clean filters should be recorded and marked with grease pencil on the face of the unit. When the reading changes by one inch, replace filter(s). A maintenance schedule should be set up for periodic reading of the manometer. Frequency can be determined by usage.

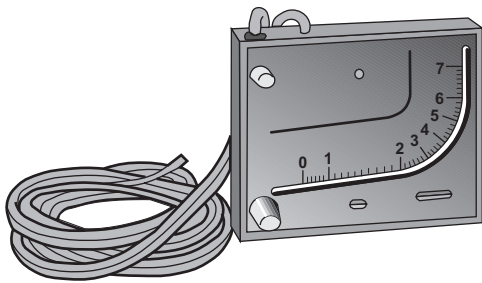

Any change in manometer reading should be investigated. It may indicate filter damage, over-pressure, or an unsafe operating condition. If it is subjected to an over-pressure, disassemble and examine for fluid in loops and tubes. Drain and re-install per instructions.

The manometer assembly requires a periodic cleaning of the exterior with water or naphtha and inspection and adjustment of the oil level. Adjust micrometer knob for zero reading as required. Add .826 sp. gr. red gauge oil when needed, to maintain zero reading.

Proper use of the manometer assembly provides a continuous indication of filter and operation conditions.

**Remove manometer when changing filters.**

### Fume Hood Evaluation in the Field

It is recommended that the user make provisions to have the following tests performed on all laboratory fume hoods. These tests should be performed by qualified personnel to verify proper operation of the fume hoods before they are put to use. Fume hood testing should be performed after the installation is complete, the building ventilation system has been balanced, and all connections made. Any unsafe conditions disclosed by these tests should be corrected before using the fume hood.

### Test Procedures

#### Test Conditions

Verify that building make-up air system is in operation, the doors and windows are in normal operating position, and that all other fume hoods and exhaust devices are operating at designed conditions.

#### Room Conditions

Check room condition in front of the fume hood using a thermal anemometer and a smoke source to verify that the velocity of cross drafts does not exceed 20% of the specified average fume hood face velocity. Any cross drafts that exceed these values shall be eliminated before proceeding with the fume hood test.

#### Equipment List

- (a) A properly calibrated hot-wire thermal anemometer.
- (b) A supply of 1/2 minute smoke bombs.

#### CAUTION

Titanium tetrachloride fumes are toxic and corrosive. Use sparingly, avoid inhalation and exposure to body, clothing and equipment.

**It must be recognized that no fume hood can operate properly if excessive cross drafts are present.**

### Face Velocity

Determine specified average face velocity for the fume hood being tested. Perform the following tests to determine if fume hood face velocities conform to specifications. With the sash at the 18" operating position, turn ON the exhaust blower. The face velocity shall be determined by averaging the velocity of six readings taken at the fume hood face. Readings shall be taken at the centers of a grid made up of three sections of equal area across the top half of the fume hood face and three sections of equal area across the bottom half of the fume hood face.

**If not in accordance with specified face velocity, refer to Troubleshooting section on page 23, for aid in determining the cause of variation in air flow.**

### Sash Operation

Check operation of the sash by moving it through its full travel. Sash operation shall be smooth and easy.

### Air Flow

#### Fume Hoods

Turn fume hood exhaust blower on. With sash in the open position, check air flow into the fume hood using a cotton swab dipped in titanium tetrachloride or other smoke source. A complete traverse of the fume hood face should verify that air flow is into the fume hood over the entire face area. Move a smoke source throughout the fume hood work area directing smoke across the work surface and baffle. Smoke should be contained within the fume hood and be rapidly exhausted.

### Face Velocity Monitor

Verify that face velocity monitor functions properly and indicates unsafe conditions.

**ANSI/ASHRAE 1110-1995**

The performance of a laboratory fume hood in providing protection for the worker at the face of the hood is strongly influenced by the laboratory room ventilation, and by other features of the laboratory in which it is installed. Therefore, there arises a need for a performance test which can be used to establish an "as manufactured" and an "as used" performance rating, including the influences of the laboratory arrangement and the overall ventilating system.

The test presumes a conditioned environment. No test can be devised which would reflect the results which would be obtained in a nonconditioned laboratory.

This procedure is a performance test method.

It remains for the user, the hygienist, or the applications engineer to specify what level of hood performance is desired or required. It should be noted that the performance test does not give a direct correlation between testing with a tracer gas and operator exposures. Many factors, such as the physical properties of the material, the rate and mode of evolution, the amount of time the worker spends at the face of the hood, and several other factors must be integrated, by a trained observer, into a complete evaluation of worker exposure. The performance test does, however, give a relative and quantitative determination of the efficiency of hood capture under a set of strict, although arbitrary, conditions. The same test can be used to evaluate hoods in the manufacturer's facilities under (presumable) ideal conditions, or under some specified condition of room air supply.

The test may be used as part of a specification once the appropriate release rate and required control level are determined. If so used, an "AM" (as manufactured) specification places a responsibility on the hood manufacturer, and an "AU" (as used) specification places responsibilities on others, including the designer of the room air supply and the designer of the room layout.

The test sheet attached to the hood reflects hood performance parameters. This sheet represents "AM" testing.

We strongly recommends that the ASHRAE 110-1995 test procedure be subjected to this hood under "AU" (as used) conditions.

Refer to the ASHRAE Standard 110-1995.

We also recommends annual verification that this above criteria is subjected to and met by all hoods at your particular facility.

**Field Evaluation of Laboratory Fume Hoods**

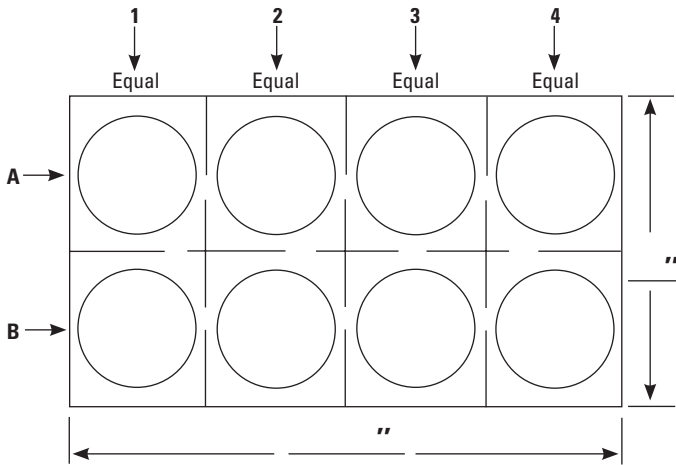

Project Name \_\_\_\_\_

Location \_\_\_\_\_

Order Number \_\_\_\_\_

Room \_\_\_\_\_ Item \_\_\_\_\_

Fume Hood Identification \_\_\_\_\_

\_\_\_\_\_

Sash Operation \_\_\_\_\_

Light Operation \_\_\_\_\_

Baffle Operation \_\_\_\_\_

Services:  A  G  V  W  NIT.  Steam

Other \_\_\_\_\_

Conclusions and Comments \_\_\_\_\_

\_\_\_\_\_  
 \_\_\_\_\_  
 \_\_\_\_\_  
 \_\_\_\_\_  
 \_\_\_\_\_  
 \_\_\_\_\_  
 \_\_\_\_\_

**Face Velocity Test**

Square footage of fume hood opening \_\_\_\_\_

Plus bypass \_\_\_\_\_

Total \_\_\_\_\_

- 1A \_\_\_\_\_ FPM
- 1B \_\_\_\_\_ FPM
- 2A \_\_\_\_\_ FPM
- 2B \_\_\_\_\_ FPM
- 3A \_\_\_\_\_ FPM
- 3B \_\_\_\_\_ FPM
- 4A \_\_\_\_\_ FPM
- 4B \_\_\_\_\_ FPM

Total \_\_\_\_\_ = \_\_\_\_\_  
 8 average

Total CFM = Average x Sq. Ft. of open sash and any bypass

I certify that the above results were obtained on \_\_\_\_\_ by \_\_\_\_\_

Evaluation procedures conducted by \_\_\_\_\_

Name

Title

Alarm Condition Functional \_\_\_\_\_

Non-functional \_\_\_\_\_

Smoke Test Positive \_\_\_\_\_

Negative \_\_\_\_\_



When fume hood test procedures detect an improper function, the cause is typically due to:

- (a) Insufficient quantity of air flowing through the fume hood;
- (b) Room cross drafts blowing into or across the face of the fume hood; or
- (c) A combination of (a) and (b).

Following are suggestions to troubleshoot the problem.

#### ■ Room Cross Drafts

Air moving through an open door located adjacent to the fume hood can cause cross drafts. An open window or a room air supply located to one side or across from the fume hood can also cause disturbing cross drafts.

High velocity air from ceiling-mounted diffusers can cause a flow of air down and into the top half of the fume hood face that can cause reverse flows of air out of the bottom half of the face.

#### ■ Insufficient Air Flow

One or more of the following conditions may exist; each condition should be checked and eliminated if possible, to determine what conditions may exist:

- (a) Inaccurate face velocity readings. Check airflow velocity meter type. Is the instrument recommended for low air velocities in the 50 to 100 feet per minute ranges? When was it calibrated last?
- (b) Verify readings with another air velocity meter or by checking air volume using a pitot tube traverse or exhaust duct.

Before contacting a service rep to assist with troubleshooting, answering the following questions will help identify where the problems have originated.

Who stated that the unit did not operate properly?

Confirm the following:

- That person's position
- That person's employer

What tests were performed?

Confirm the following:

- Instruments used
- When it was last calibrated
- Calibration results

What is the fume hood type?

Confirm the following:

- Fume hood model
- Fume hood size

Is the location of fume hood acceptable?

Are cross currents present?

- Determine whether there is traffic past the fume hood.

Is adequate free or make-up air available?

Confirm the following:

- Whether the air is readily available
- The supply source of air
- Whether it can be altered or cut off

Did the fume hood ever function properly?

- Determine whether authorized modifications been made and when.

Have recent changes been made in the laboratory heating/cooling system?

- If so, describe.

**DO NOT DISCARD  
IMPORTANT TEST AND  
CALIBRATION DATA  
ENCLOSED!**

**TO BE REMOVED ONLY BY HOOD USER**

©2015 Hamilton Laboratory Solutions. All rights reserved.

Hamilton Laboratory Solutions

825 East Albert Drive  
Manitowoc, WI 54220

920.657.1970  
[www.hamiltonlab.com](http://www.hamiltonlab.com)

PL-1018-4 PN70017 1115

